

WPA World Artistic Pool Championship

2012

Official Shot / Challenge Program

Revision History

- November 30, 2010: Initial version of shot program.
- January 10, 2011: Discipline 7 – Shot 3a: revised cue ball position requirements.
- February 14, 2011: Discipline 1 – Shot 1b: revised cue ball position requirements.
Discipline 2 – Shot 2d: revised prop position requirements.
Discipline 5 – Shot 4c: fixed typo.
Discipline 6 – Shot 2d: clarified Special Notes.
Discipline 8 – Shot 5a: added Special Notes.
Added General Rules 13 and 14.
- February 18, 2011: Clarified General Rules 5 and 6.
- October 31, 2011: WPA Artistic Pool Division extensive statistical analysis review updates implemented including, but not limited to, a reduction of the total shot / challenge selections to 120 with relabeled A, B, C designations for each of the 5 shots / challenges remaining in each discipline. In addition, several approved challenge proposals included as follows:
- Discipline 1 – Shot 4C was moved / updated to a 5B challenge with revised text
 - Discipline 2 – Challenge 4A (wing shots) format / scoring updated with revised text
 - Discipline 2 – Challenge 4C (juggle shot) setup / scoring updated with revised text
 - Discipline 2 – Challenge 5C updated with revised text under special notes
 - Discipline 3 – Shot 2C updated with new objective and revised diagram / text
 - Discipline 4 – Shot 3C updated cue ball position with revised text
 - Discipline 8 – Shot 2D was moved / updated with new DOD as a 1C challenge
 - Tiebreaker Challenge – Dollar bill shot included on last page of program

Special Note: All 10/31/11 revisions / updates were approved by the WPA APD after a complete and careful review of the 2011 program and the percentage make rates of the challenges attempted in the 2011 WPA World Artistic Pool Championship. Considerations also included player physical limitations and potential injury of repeated attempts on some shots. The “classic” nature and challenge of the program was also considered, whereby players would experience competitive fairness, and everyone would see more shots being made to increase interest to our sport from players, fans, media contacts, and sponsors around the world.

General Rules

The following general rules will apply to all shots, unless specifically overridden by shot description.

1. All shots will be judged based on the intent of the shot. If any loophole is found that changes the intent of the shot, those changes to the shot will not be allowed.
2. Any balls or object specified as 'ball-in-hand' may be placed anywhere on the table, provided that the intent of the shot is preserved.
3. Any balls or object specified as 'ball-in-hand' but has additional positioning requirements may be adjusted freely by the player provided that the additional requirements are met.
4. All balls specified as 'hanging near a pocket' may be freely adjusted by the player near that pocket within reason.
5. Any object or ball that must be positioned within a zone must be completely in that zone.
6. Any ball that must come to rest within a zone will be considered in that zone if any part of the ball is within the zone, measured by the edge of the ball.
7. All chalk cubes placed on the table must be well up, and must be square with the table (may not be rotated), unless otherwise stated.
8. All measurements of 1 chalk's width will be measured with a cue of chalk held at mid-ball height (the widest part of the ball), unless otherwise stated.
9. It is always okay for a ball to contact an extra cushion near a ball hanging in a pocket, unless otherwise stated.
10. It is always okay for the cue ball to scratch, unless otherwise stated.
11. At no time may any ball (cue ball or object ball) fly off the table.
12. Players are free to shoot the mirror image of any shot. Please note that rotating a shot 90 degrees is not the mirror image and will not be allowed.
13. Players are free to shoot any part of any shot with either hand.
14. Players may not switch cues during a shot unless otherwise specified or due to equipment failure.
15. The decision by the table judge is final.

DISCIPLINE

1

TRICK & FANCY SHOTS

Discipline 1 – Shot 1a – 6 points

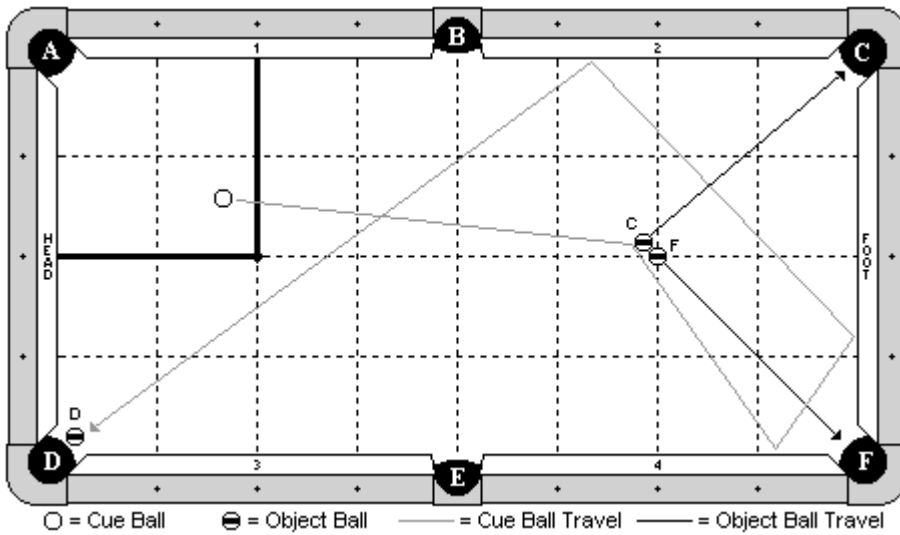

Cue Ball

In hand within the indicated zone.

Object Balls

'C' and 'F' balls frozen with 'F' ball on the foot spot and 'C' ball adjustable. 'D' ball hanging near pocket 'D'.

Objective

Shoot the cue ball into 'C' ball. 'C' and 'F' balls will go into pockets as diagrammed. The cue ball will travel 3 cushions as diagrammed, and make 'D' ball.

Special Notes

None

Discipline 1 – Shot 1b – 6 points

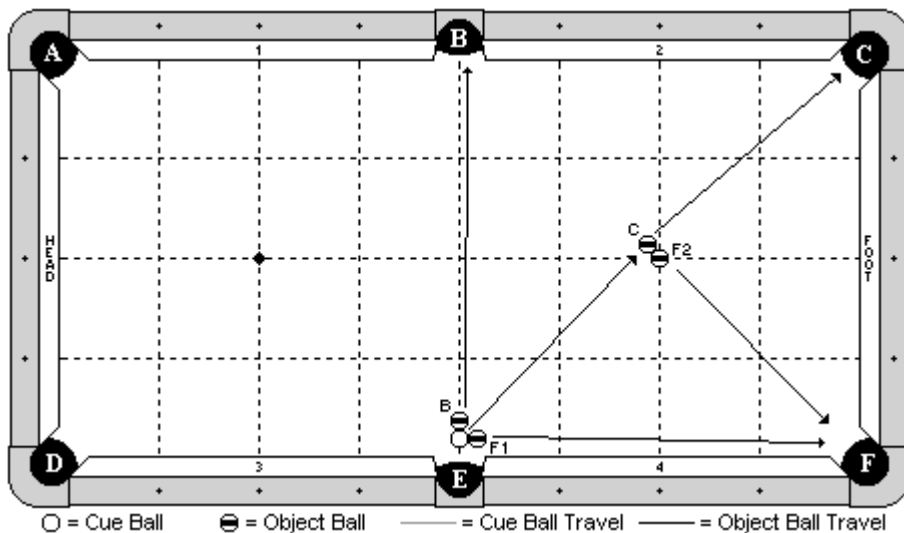

Cue Ball

In hand, within two ball widths of slate cut of pocket 'E'.

Object Balls

'B' and 'F1' balls are in hand, frozen to the cue ball. 'C' and 'F2' balls are frozen with 'F2' ball on the foot spot and 'C' ball adjustable.

Objective

Shoot the cue ball towards 'C' ball. All 4 balls will go as diagrammed.

Special Notes

'F1' ball will go into pocket 'F' before 'F2' ball is made in the same pocket.

Discipline 1 – Shot 1c – 6 points

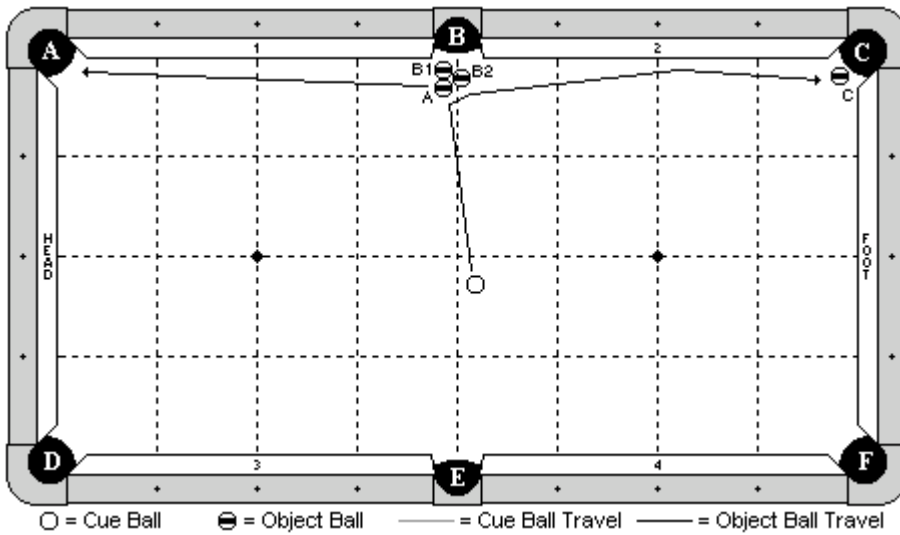

Cue Ball

In hand, behind the long center line of the table.

Object Balls

All object balls as diagrammed and adjustable.

Objective

Shoot the cue ball into 'A' ball. 'A' ball will go into pocket 'A'. 'B1' will go into pocket 'B' by the combination with the 'A' ball. Cue ball will carom off and make 'B2' ball into pocket 'B'.

Cue ball will carom off and travel down the cushion to make 'C' ball.

Special Notes

None

Discipline 1 – Shot 2a – 7 points

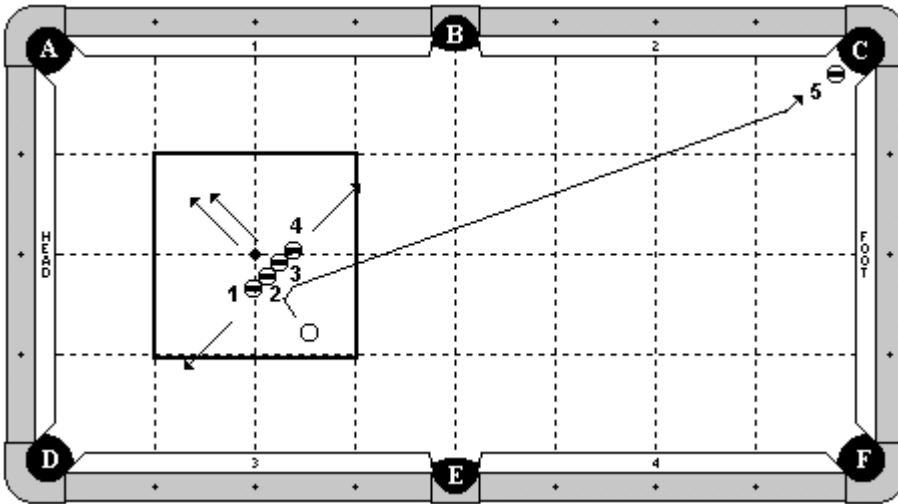

Cue Ball

In hand

Object Balls

Balls 1-4 are as diagrammed and adjustable. The 1 & 2 balls must be frozen. The 3 & 4 balls must be frozen. The 2 & 3 balls may be frozen or may have a small gap between them (no larger than a chalk). The 5 ball is hanging near pocket 'C'.

Objective

Shoot the cue ball into the 2 ball. The 1 ball will go into pocket 'D'. The 2 & 3 balls will go into pocket 'A'. The 4 ball will go into pocket 'B'. The cue ball will carom off and make the 5 ball in pocket 'C'.

Special Notes

None

Discipline 1 – Shot 2b – 7 points

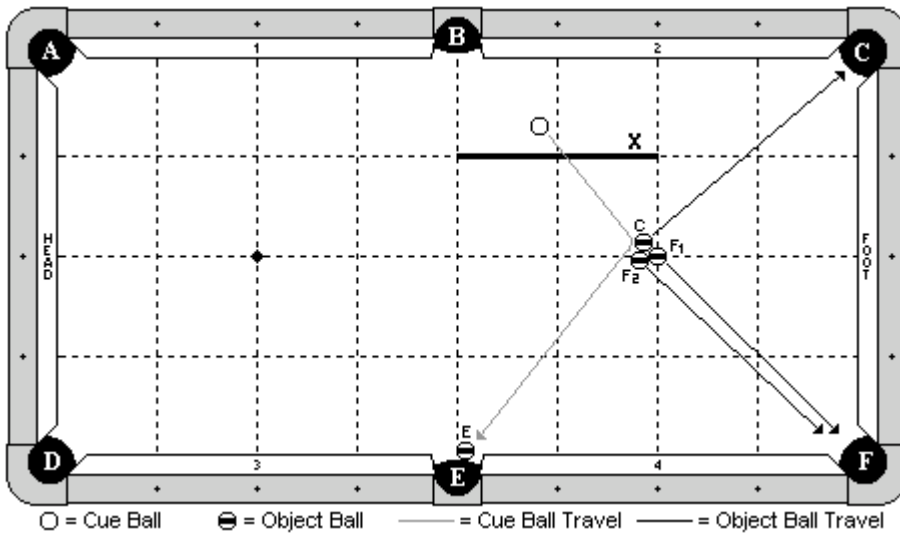

Cue Ball

In hand behind 'X' line.

Object Balls

A cluster of 3 balls is frozen as diagrammed, with 'F1' ball on the foot spot. 'E' ball is hanging near pocket 'E' and is adjustable.

Objective

Shoot the cue ball into 'C' ball. 'C' and 'F1' balls will go as diagrammed. The cue ball will carom off into 'F2' ball, making it in pocket 'F'. The cue ball will carom off and make 'E' ball.

Special Notes

None

Discipline 1 – Shot 2c – 7 points

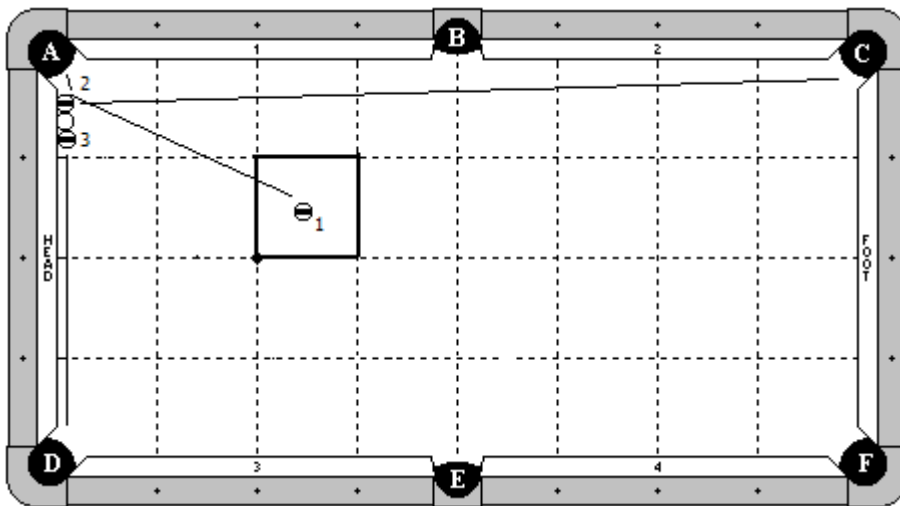

Cue Ball

Frozen to the head cushion and frozen to the 2 & 3 balls.

Object Balls

1 ball in hand within indicated zone. 2 ball frozen to the cushion and to the cue ball. 3 ball frozen to the cue ball, but does not need to be frozen to the cushion.

Objective

Shoot the 1 ball into the 2 ball. The 1 ball will go into pocket 'A'. The 2 ball will bank into pocket 'C'. The 3 ball will go into pocket 'D'.

Special Notes

At the conclusion of the shot, the cue ball may not be more than 1 chalk's width away from the head cushion.

Discipline 1 – Shot 3a – 8 points

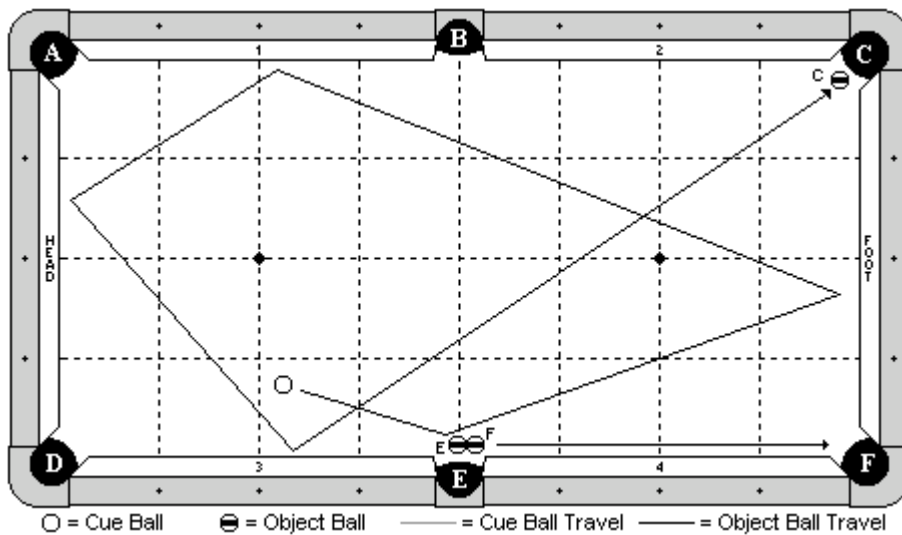

Cue Ball

In hand.

Object Balls

'E' and 'F' balls are as diagrammed and adjustable. 'C' ball is hanging near pocket 'C'.

Objective

Shoot the cue ball and make 'E' ball in pocket 'E', and 'F' ball in pocket 'F'. The cue ball will travel 4 cushions as diagrammed and make 'C' ball.

Special Notes

None

Discipline 1 – Shot 3b – 8 points

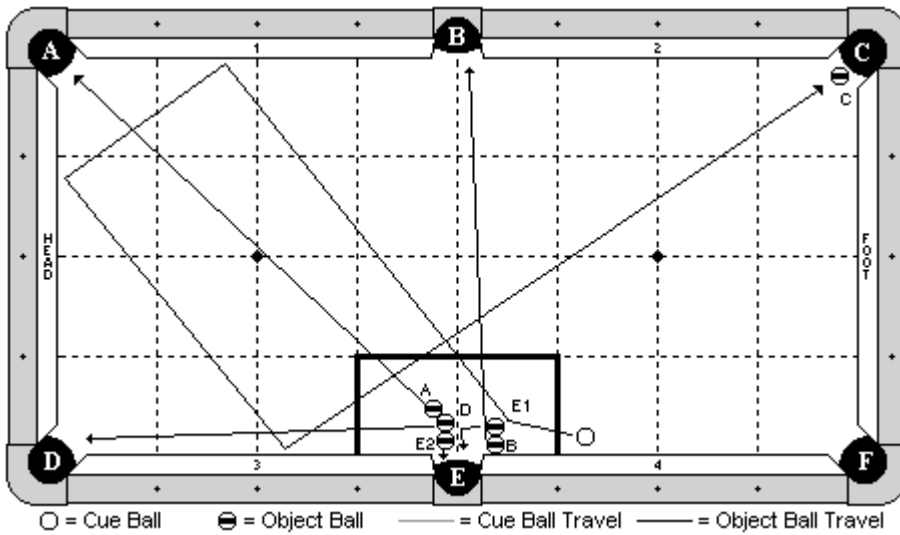

Cue Ball

In hand.

Object Balls

'E1' and 'B' balls are frozen, with 'B' ball also frozen to the cushion. 'D' ball is frozen to both 'A' and 'E2' balls. All 5 balls are adjustable within the box zone. 'C' ball is hanging near pocket 'C'.

Objective

Shoot the cue ball to 'E1' ball. All 5 balls will go as pocket letter designates. The cue ball will travel 3 cushions to make 'C' ball.

Special Notes

None

Discipline 1 – Shot 3c – 8 points

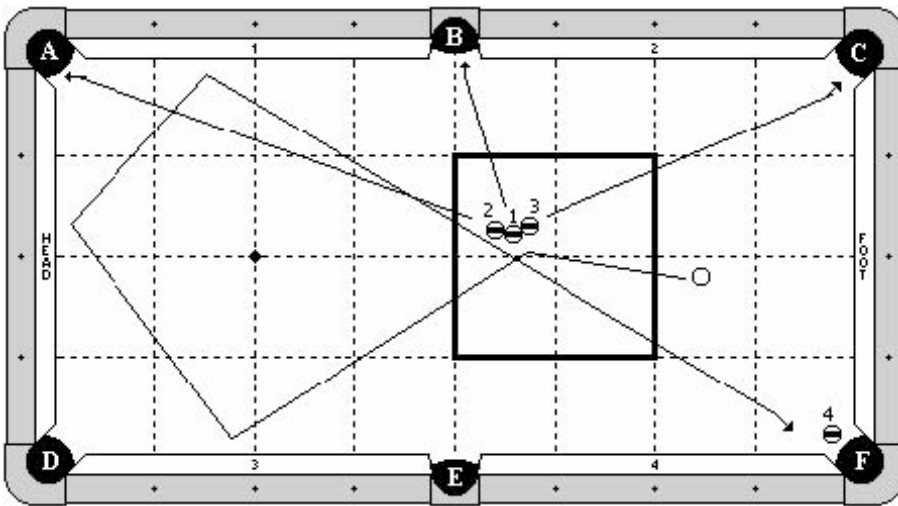

Cue Ball

In hand behind the second diamond.

Object Balls

Balls 1,2,3 are in hand as diagrammed within the indicated zone. Ball 4 is hanging near pocket 'F'.

Objective

Shoot the cue ball into the 1 ball, causing the 3 balls to split as diagrammed and go into pockets A,B & C. The cue ball will travel 3 cushions as diagrammed and make the 4 ball in pocket F.

Special Notes

None.

Discipline 1 – Shot 4a – 9 points

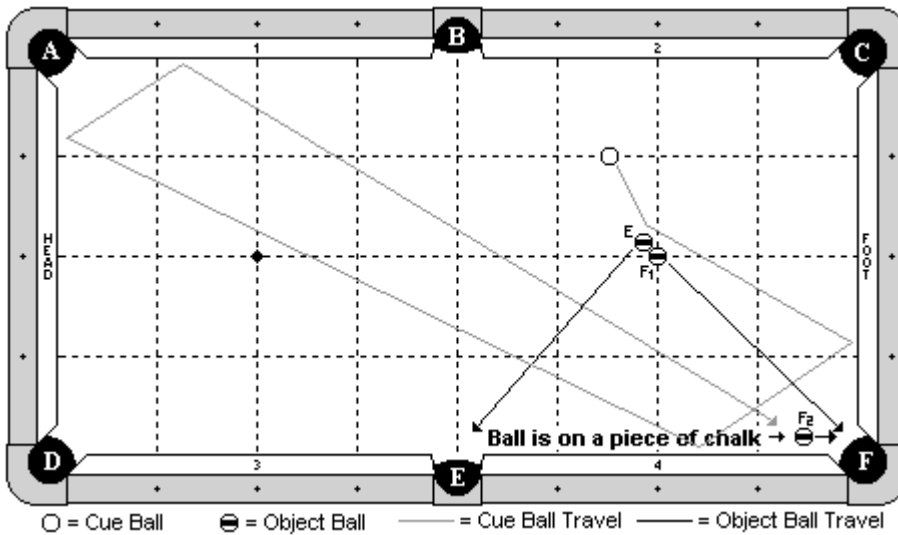

Cue Ball

In hand

Object Balls

'F1' ball on foot spot. 'E' ball frozen to 'F1' ball and adjustable. 'F2' ball balanced on a piece of new chalk (well up). 'F2' ball is adjustable.

Objective

Shoot the cue ball into 'E' ball. 'E' ball will go in pocket 'E'. 'F1' ball will go in pocket 'F'. The cue ball will travel 4 cushions as diagrammed, knock 'F2' ball off the chalk and into pocket 'F'.

Special Notes

The cue ball must knock 'F2' ball off the chalk. If 'F2' ball is knocked off by another ball before the cue ball gets there, the shot is no good.

Discipline 1 – Shot 4b – 9 points

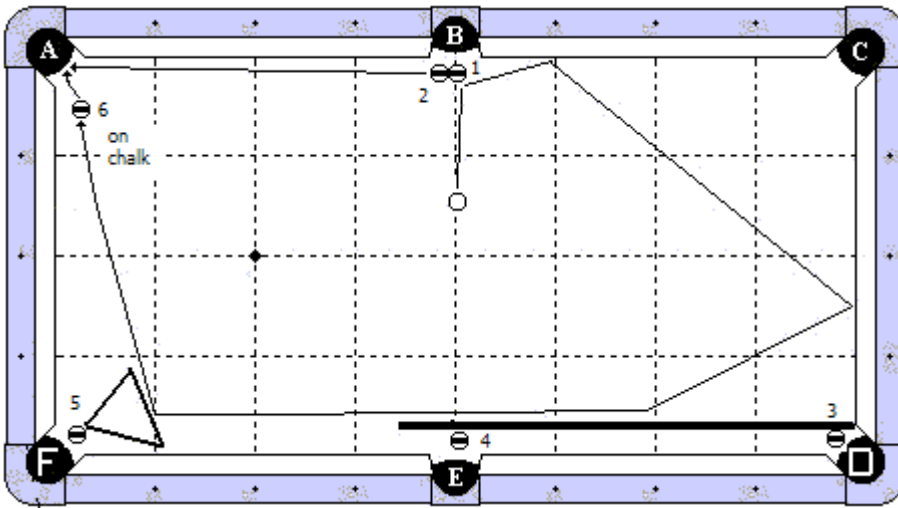

Cue Ball

In hand, behind the 1st diamond line from pocket 'B'.

Object Balls

1 & 2 balls near pocket 'B'. 3 ball near pocket 'D', frozen to the butt end of the cue stick. 4 ball near pocket 'E', frozen to the cue stick. 5 ball near pocket 'F' with a rack positioned as diagrammed. 6 ball in hand near pocket 'A', balanced on a piece of new chalk (well up).

Objective

Shoot the cue ball into the 1 ball. The 1 ball will go in pocket 'B' and the 2 ball will go in pocket 'A'. The cue ball will travel the indicated path, hit the cue stick, causing the 3 and 4 balls to be made in their corresponding pockets. The cue ball will then hit the rack, making the 5 ball, and then hit the 6 ball, knock it off the chalk, and make it in pocket 'A'.

Special Notes

The cue ball may hit the long cushion before hitting the rack. The 6 ball must be knocked off the chalk by the cue ball. Players selecting this shot will be required to provide the cue stick.

Discipline 1 – Shot 4c – 9 points

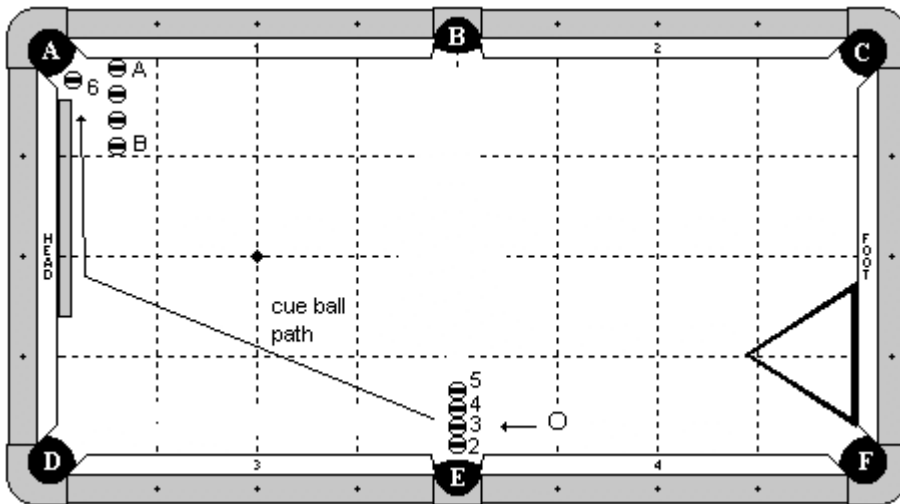

Cue Ball

In hand, on or behind the 3rd diamond line.

Object Balls

Balls 2,3,4,5 are frozen and adjustable. 6 ball is hanging near pocket 'A'. 4 blocking balls are along the ½ diamond line, with the first ('A') ball frozen to the cushion and 1 ball gaps between the others. A rack is frozen to the foot cushion as diagrammed and adjustable. A cue stick butt is frozen to the head cushion and adjustable.

Objective

Shoot the cue ball into the line of balls. The 2 ball will go into pocket 'E', the 3 ball into pocket 'D', the 4 ball will bank into pocket 'F', and the 5 ball will go into pocket 'B'. The cue ball will follow down table, optionally hitting the long cushion, hit the cue stick butt, and make the 6 ball.

Special Notes

The cue ball may not contact any of the blocking balls until after the 6 ball is made. Players selecting this shot will be required to supply the cue stick butt.

Discipline 1 – Shot 5a – 10 points

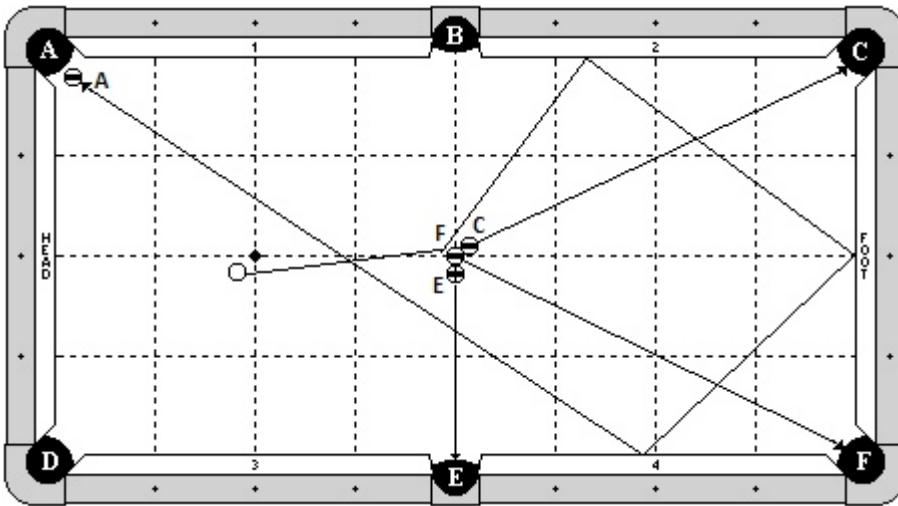

Cue Ball

In hand behind the head string.

Object Balls

'F' ball is exactly in the center of the table. C and E balls are frozen to ball F and adjustable. A ball is hanging by pocket A.

Objective

Shooting the cue ball to F ball, make all 3 balls as pocket letters designate. The cue ball will then travel 3 rails as diagrammed and make A ball.

Special Notes

None.

Discipline 1 – Shot 5b – 10 points

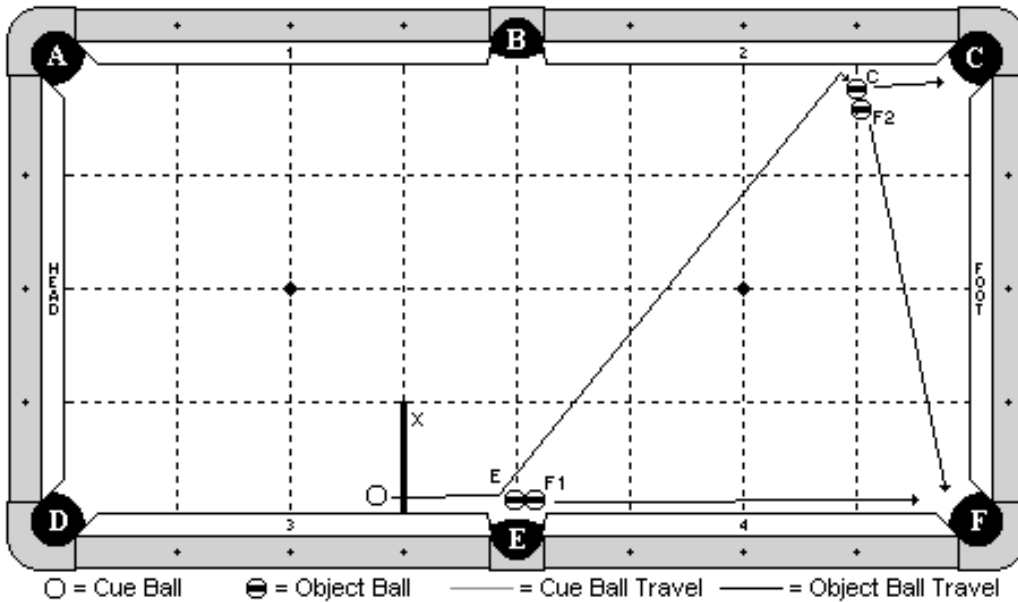

Cue Ball

In hand behind 'X' line.

Object Balls

'E' and 'F1' balls are frozen and adjustable near pocket 'E'. 'C' and 'F2' balls are frozen and adjustable as diagrammed, with 'C' ball being on the 1st diamond line and no more than 1 ball's width from the cushion.

Objective

Shoot the cue ball into 'E' ball, and then carom into cushion 2 and kick into 'C' ball. All balls will go as pocket letter designates.

Special Notes

None

Discipline 1 – Shot 5c – 10 points

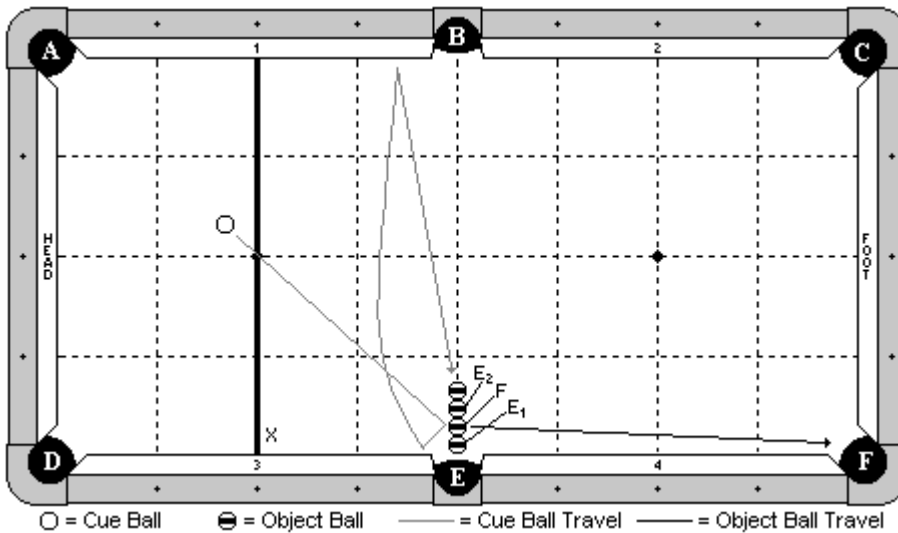

Cue Ball

In hand behind head string, as indicated by line X.

Object Balls

All four object balls are in a straight line, parallel to the head and foot cushions. The object ball closest to pocket E ('E1') has its edge even with the edge of the cushion.

Objective

Shoot cue ball to 'F' ball. 'F' ball will make in pocket 'F' and 'E1' ball will make in pocket 'E'. Cue ball will contact cushion 3, bank across to cushion 1, and come back, making the two ball combination ('E2' ball will make in pocket 'E'). The ball closest to the center of the table does not have to be made.

Special Notes

None.

DISCIPLINE

2

PROP / NOVELTY / SPECIAL ARTS

Discipline 2 – Shot 1a – 6 points

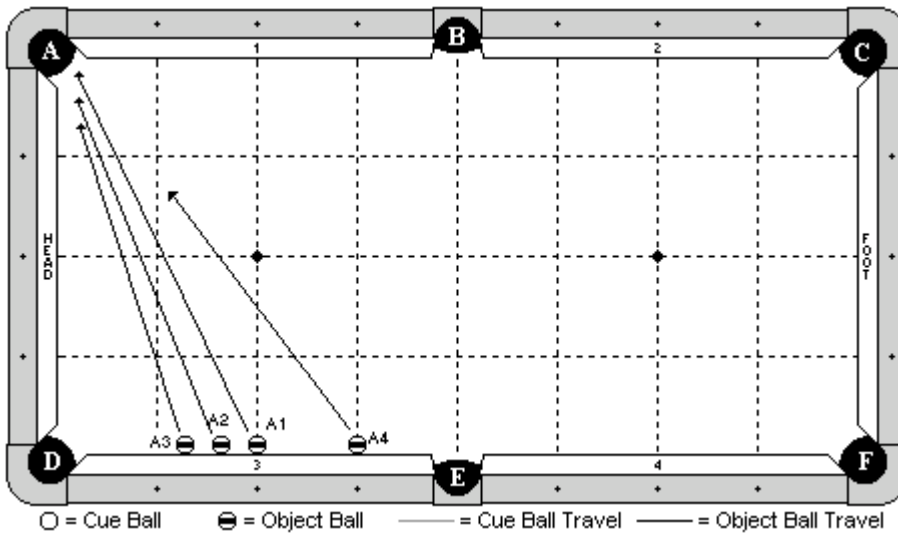

Cue Ball

None

Object Balls

4 balls are placed frozen to cushion 3 as diagrammed. 'A4' ball is on the 3rd diamond line. 'A1' ball is on the 2nd diamond line. 'A1', 'A2' and 'A3' balls are spaced with 1 ball gaps between them.

Objective

Shoot 'A4' ball towards pocket 'A'. Quickly shoot balls 'A1', 'A2', and 'A3' in order into pocket 'A'. The balls will go into pocket 'A' in numerical order as indicated by their ball number.

Special Notes

It is recommended that players use balls in numerical sequence for this shot. It is okay for the balls to contact each other as they are rolling, provided that they go into the pocket in the following order: 'A1', 'A2', 'A3', 'A4'.

Discipline 2 – Shot 1b – 6 points

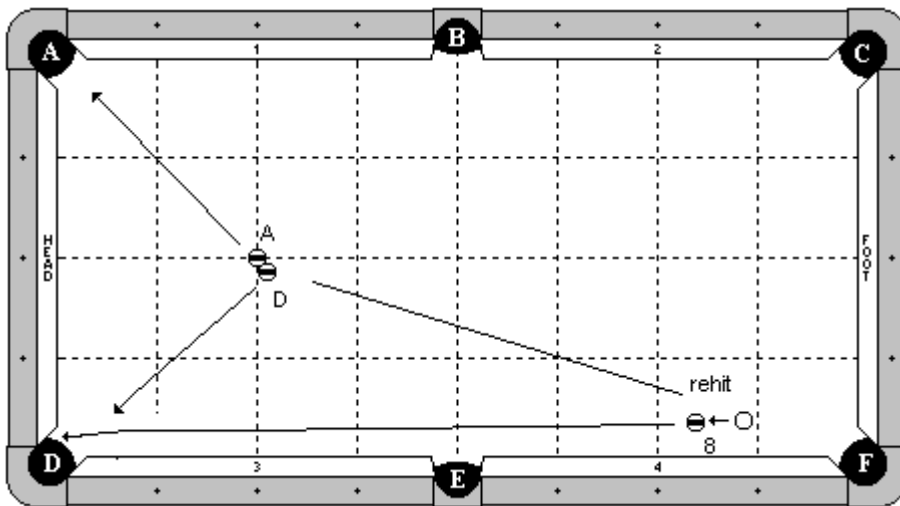

Cue Ball

In hand behind the 2nd diamond line.

Object Balls

8 ball in hand behind the 2nd diamond line. 'A' ball on the head spot. 'D' ball frozen to 'A' ball and adjustable.

Objective

Shoot the cue ball into the 8 ball. Re-hit the cue ball into 'D' ball, causing the 'D' and 'A' ball to be made as pocket letter designates. The 8 ball will go into pocket 'D' last.

Special Notes

None

Discipline 2 – Shot 1c – 6 points

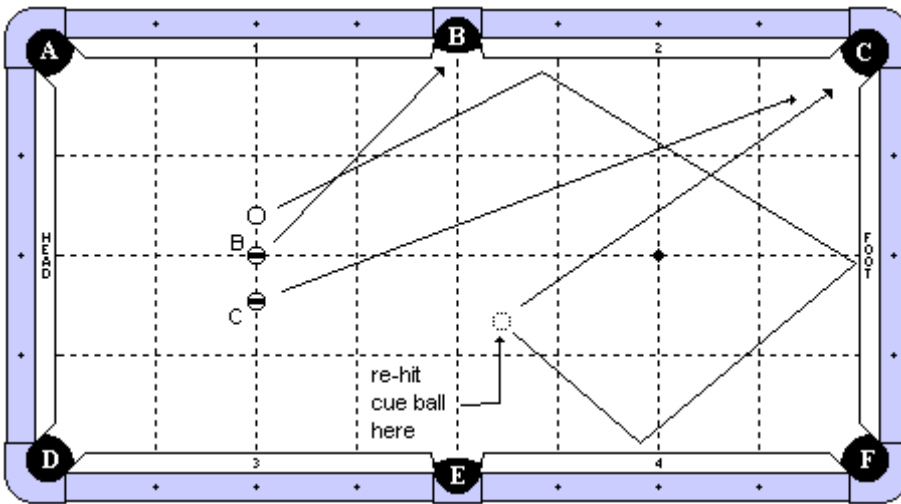

Cue Ball

In hand, on head string, to the left of 'B' ball.

Object Ball

'B' ball on head spot.

'C' ball in hand on head string to the right of 'B' ball.

Objective

Hit the cue ball first. It will travel three rails approximately to the marked point. While the cue ball is rolling, shoot 'B' ball into pocket 'B'. Then shoot 'C' ball towards pocket 'C'. Re-hit cue ball into pocket 'C'. The cue ball must go in to pocket 'C' before 'C' ball.

Special Notes

The cue ball must be rolling when hit a second time.

Discipline 2 – Shot 2a – 7 points

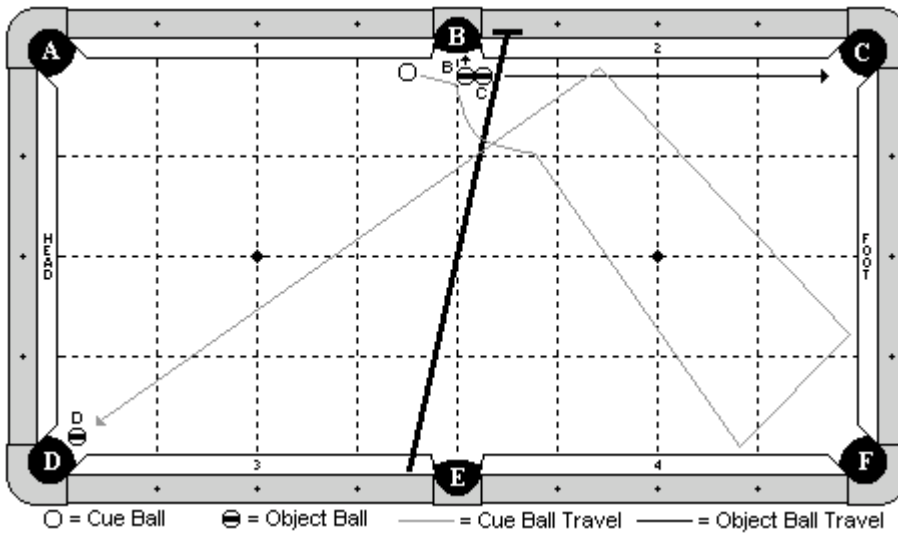

Cue Ball

In hand

Object Balls

'B' and 'C' balls frozen near pocket 'B' and adjustable. 'D' ball hanging near pocket 'D'. The bridge is on the rail tops, with the head of the bridge near pocket 'B'. The player has the option to prop up the butt end of the bridge with a chalk cube.

Objective

Shoot the cue ball into 'B' ball. 'B' and 'C' balls will go as pocket letter designates. The cue ball will jump over the bridge, travel three cushions as diagrammed, and make 'D' ball.

Special Notes

The cue ball may hit the bridge.

Discipline 2 – Shot 2b – 7 points

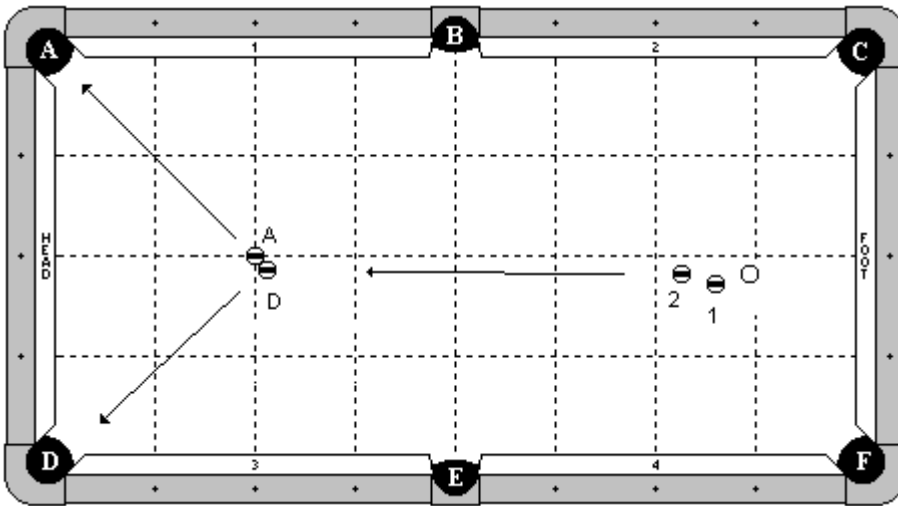

Cue Ball

In hand, exactly 3 ball's width from the 2 ball.

Object Balls

2 ball is in hand behind the 2nd diamond line, exactly 3 ball's width from the cue ball. 1 ball is centered between the cue ball and 2 ball, and is ½ ball offset in either direction. 'A' ball is on the head spot. 'D' ball frozen to 'A' ball and adjustable.

Objective

In one forward motion stroke, shoot the cue stick through the cue ball and into the 2 ball. The 2 ball will travel forward and make 'D' and 'A' balls as pocket letter designates.

Special Notes

This shot must be performed in one continuous forward motion. Decision of the table judge is final.

Discipline 2 – Shot 2c – 7 points

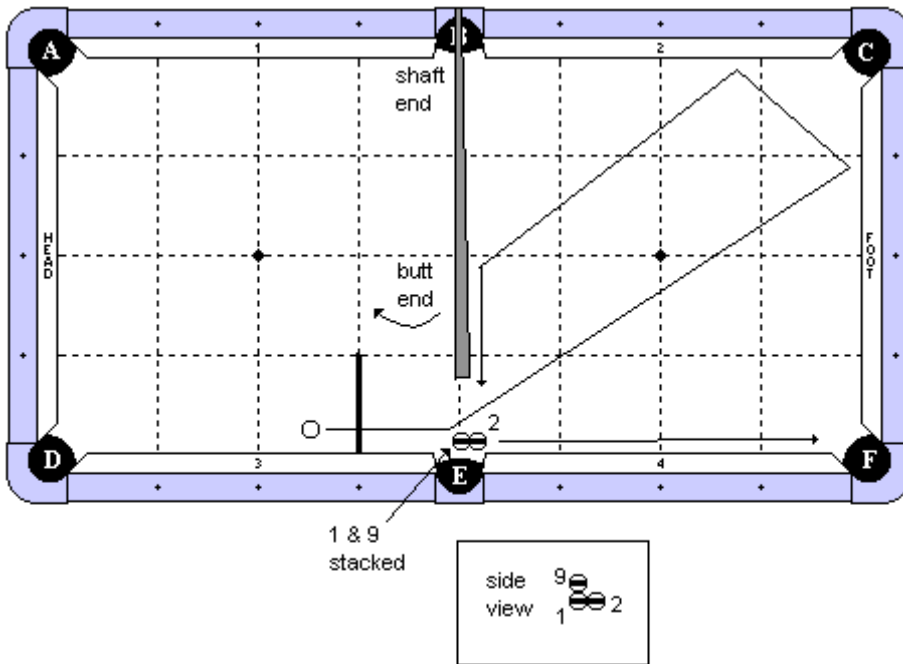

Cue Ball

In hand behind 3rd diamond line, as indicated.

Object Balls

The 1 ball is a special stacking ball near pocket E. The 2 ball is frozen to the 1 ball. The 9 ball is balanced on top of the 1 ball.

Props

A regular cue stick is laying with the tip end balanced on the rail top. The cue stick must cross the rail within one half diamond or be on top of pocket 'B'. The butt end of the cue stick may not be closer than 4 ball's width to the setup.

Objective

Shoot the cue ball into the 1 ball. The 1 ball will go into pocket E and the 2 ball will go into pocket F. The cue ball will travel 2 cushions, hit the stick, and make the 9 ball.

Special Notes

None.

Discipline 2 – Shot 3a – 8 points

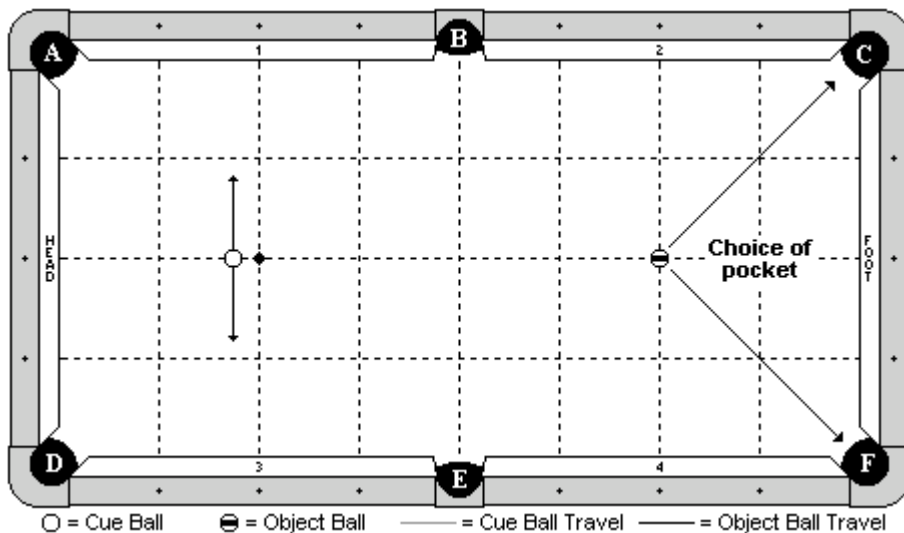

Cue Ball

In hand behind the 2nd diamond.

Object Balls

On foot spot.

Objective

Shoot the cue ball one handed, jacked up (no rail or bridge allowed), and make the object ball in either pocket 'C' or 'F' (player's choice).

Special Notes

Unless obvious from the placement, the player must designate which pocket the object ball will go into.

Discipline 2 – Shot 3b – 8 points

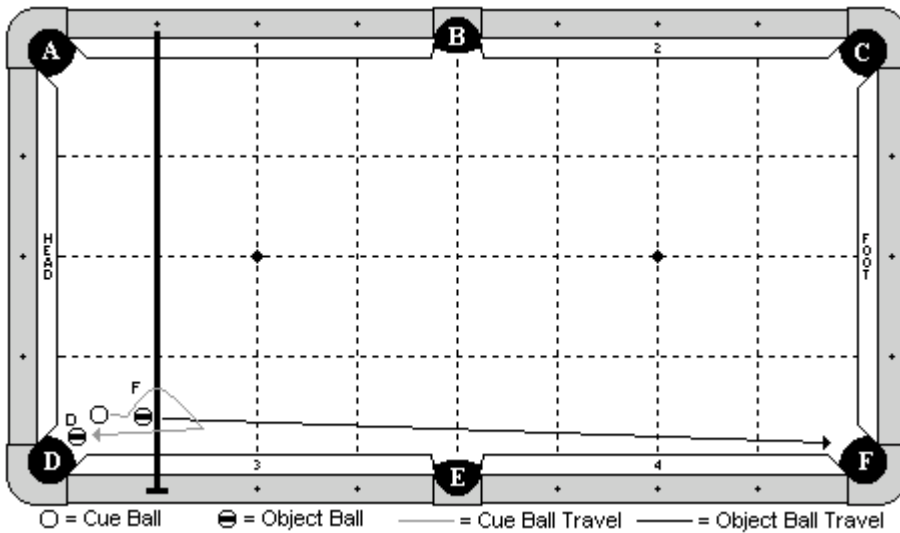

Cue Ball

In hand within 1x1 diamond zone near pocket 'D'.

Object Balls

'F' ball in hand within 1x1 diamond zone near pocket 'D'. 'D' ball hanging near pocket. Bridge is on the rail top along the 1st diamond. Players have the option of propping up the bridge with any object.

Objective

Shoot the cue ball into 'F' ball, making it in pocket 'F'. The cue ball will jump over the bridge, and draw back under it, to make 'D' ball.

Special Notes

The bridge may be contacted without penalty. The cue ball may contact cushion 3 or the head cushion prior to making 'D' ball, but no other cushion.

Discipline 2 – Shot 3c – 8 points

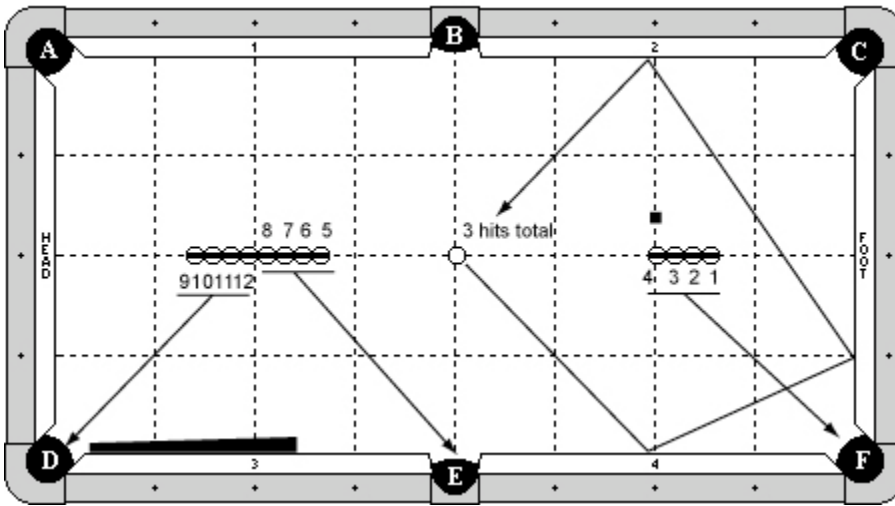

Cue Ball

On center spot.

Object Balls

1-4 balls frozen on center line with 4B on spot. 5-8 balls frozen on center line. 9-12 balls frozen on center line. 8B and 12B frozen, splitting the spot. Cue stick butt frozen to cushion 3. A piece of chalk is on the foot string, even with the 4B and 1 ball's width away.

Objective

Shoot CB around the chalk. Shoot 1,2,3,4 balls into pocket F in order. Re-hit CB around the chalk. Shoot 5,6,7,8 balls into pocket E in order. Re-hit CB around chalk so it will eventually go into pocket D. Shoot 9-12 balls into pocket D in order before CB gets there.

Special Notes

Only CB may hit cue stick butt. Chalk may not be contacted by any means. CB may never stop. No balls may be disturbed except the ball being shot. Balls will be pocketed in the following order: 1-12,CB. Balls may not hang up and be made by the next ball. There is no requirement to shoot any balls left-handed, however, the player may do so at their own discretion.

Discipline 2 – Shot 4a – 9 points maximum

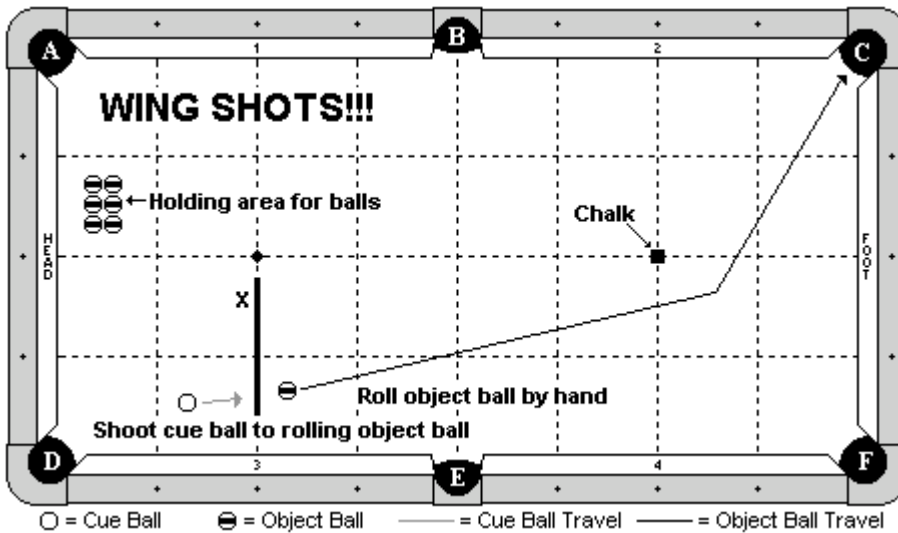

Cue Ball

Starts in the player's hand.

Object Balls

Object balls start on the table as diagrammed. There are a total of 9 object balls on the table – 1 in hand and 8 in the holding area. The diagram has not been updated and shows 6 object balls in the holding area. Player will start with one object ball and place it in his hand along with the cue ball. A chalk cube is aligned as diagrammed and placed on the foot spot.

Objective

Roll the object ball down the table as diagrammed. Position the cue ball behind the head string. Shoot the cue ball into the rolling object ball and make it in pocket 'C'. Repeat with 2 more object balls. Note: An attempt consists of 3 wing shots.

Special Notes

The object ball must be rolling when hit by the cue ball. The object ball must be hit by the cue ball before it hits the foot cushion. No abort rolls. The chalk may not be hit by the object ball. Use of a guide when rolling the object ball is not allowed.

Special Scoring (per attempt)

Make 1 wing shot: 3 points
Make 2 wing shots: 6 points
Make 3 wing shots: 9 points

Players are given 3 attempts with 3 object balls for each attempt.

Note: Best score of 3 attempts will be counted for final score.

Discipline 2 – Shot 4b – 9 points maximum

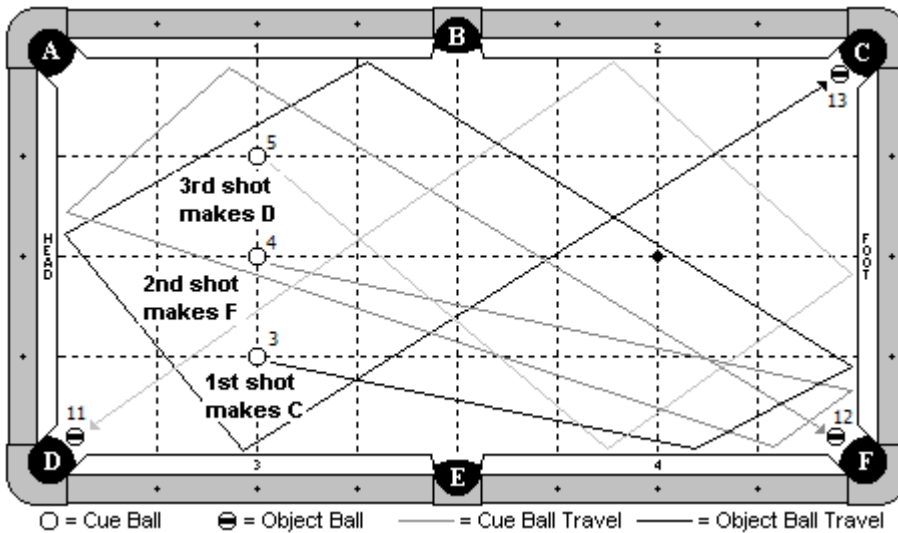

Cue Ball

None

Object Balls

Three object balls are placed on the head string, with the center ball on the head spot. It is recommended that the player use the 5, 4 & 3 balls as diagrammed. Three other object balls are placed near their corresponding pockets. It is recommended that the player use the 13, 12, & 11 balls as diagrammed.

Objective

Shoot the 5 ball first, 5 cushions as diagrammed, to make the 13 ball. Shoot the 4 ball second, 4 cushions as diagrammed, to make the 12 ball. Shoot the 3 ball third, 3 cushions as diagrammed, to make the 11 ball.

Special Notes

The player will be timed on this shot. The clock will start when the 5 ball is struck and it will stop when the 3 ball is struck. Players have a maximum of 4 seconds to perform this shot.

Special Scoring

Make any 1 ball: 3 points

Make any 2 balls: 6 points

Make any 3 balls: 9 points

Players are given three attempts. The highest scoring attempt will be used.

Discipline 2 – Shot 4c – 9 points maximum

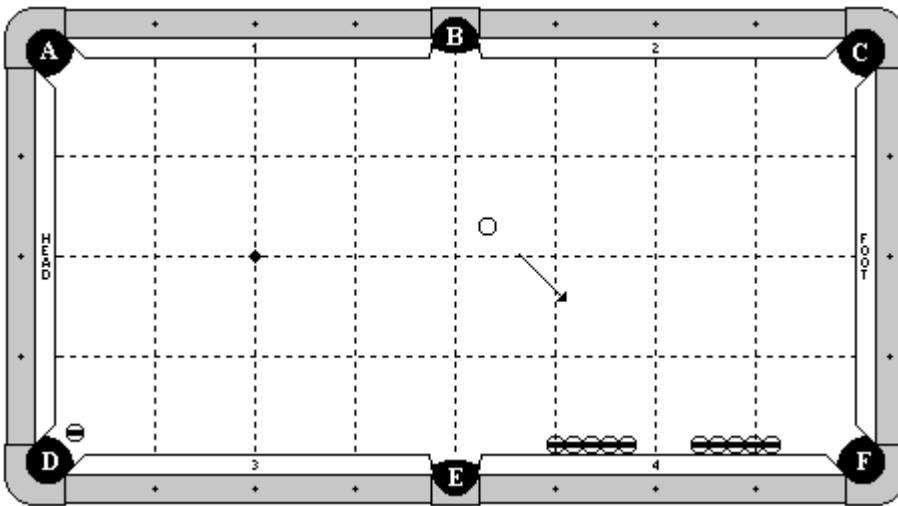

Cue Ball

In hand.

Object Balls

One object ball hanging near pocket 'D'.

Two rows of 5 object balls are frozen against cushion 4 with exactly a 4 ball gap in between them. End balls may not be past the point of pocket 'F' or 'E'.

Objective

Shoot the CB through the gap around 3 rails. Re-hit the moving CB through the gap around 3 rails. Re-hit the moving CB a second time through the gap around 3 rails. Re-hit the moving CB a third time through the gap and around 3 rails, making 'D' ball in pocket 'D'.

Special Notes

The cue ball must be moving when it is re-hit each of the three times.

The rows of blocker balls may not be contacted by any means during the shot.

Special Scoring

First hit through the gap and CB goes three rails. No points awarded yet.

First re-hit through the gap and CB goes three rails: 3 points.

Second re-hit through the gap and CB goes three rails: 6 points.

Third re-hit through the gap, CB goes three rails, and must make of OB in pocket D: 9 points

Examples: If a player successfully re-hits the CB and goes 3 rails the first time, but misses the second time in any way, the attempt is scored as 3 points. If a player successfully re-hits the CB and goes 3 rails the 2nd time, but misses the 3rd time in any way, the attempt is scored as 6 points.

The CB must hit cushions 4, foot, and 2 for points to be awarded for the hit. Hitting the point of pocket 'C' such that the CB re-hits the foot cushion does not count as a successful hit. Table judge's decision is final.

Players are given three attempts. The highest scoring attempt will be used.

Discipline 2 – Shot 5a – 10 points

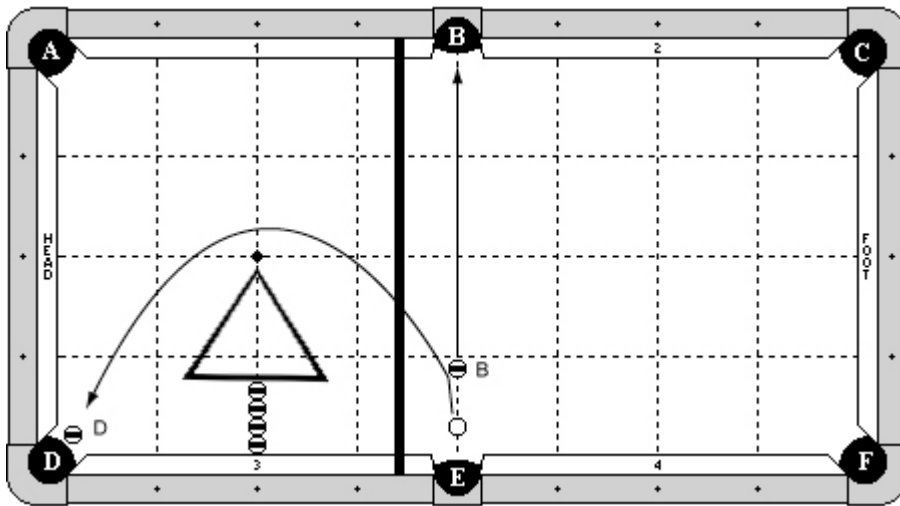

Cue Ball

In hand, but may not be more than 3 ball's width from the long rail.

Object Balls

'B' ball is along the center line of the table and adjustable. 'D' ball is hanging near pocket 'D'. A bridge is on the rail tops, no more than 1 diamond from pocket 'D'. A rack is placed as diagrammed, centered on the head string, and exactly 4 balls off the cushion.

Objective

Shoot the cue ball into 'B' ball, making it in pocket 'B'. The cue ball will jump over the bridge, draw around the rack, and make 'D' ball.

Special Notes

The cue ball may contact the bridge, but not the rack until after 'D' ball is made.

Discipline 2 – Shot 5b – 10 points

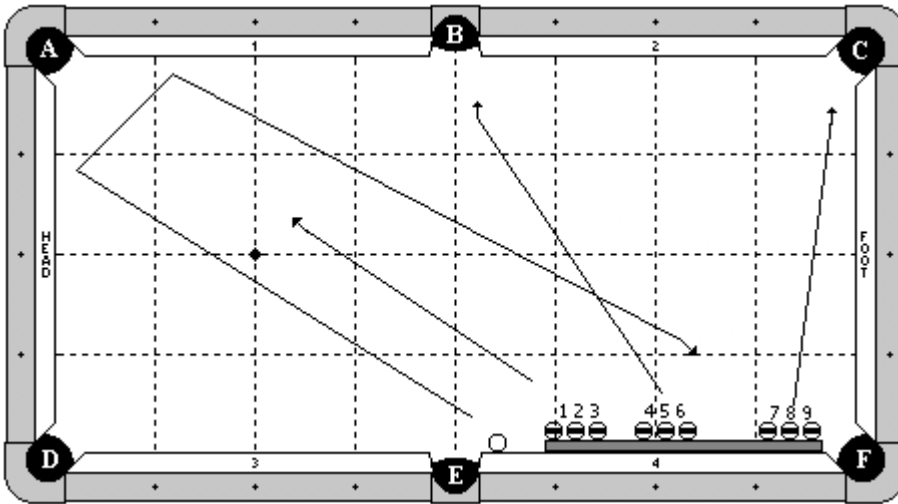

Cue Ball

In hand between pockets 'E' and 'F', frozen to either the cushion or cue stick.

Object Balls

Object balls 1 through 9 are in hand between pockets 'E' and 'F', frozen to either the cushion or cue stick. All balls (cue ball and object balls) must be in the order in which they are diagrammed. A cue stick butt is frozen to the cushion as diagrammed.

Objective

Shoot the cue ball 2 cushions as diagrammed. While the cue ball is rolling, shoot the 1,2,3 balls in pocket 'A', 4,5,6 balls in pocket 'B', and 7,8,9 balls in pocket 'C'. The cue ball will then go into pocket 'F', possibly with the help of the cue stick butt.

Special Notes

All of the balls must be struck and pocketed in numerical order as diagrammed. The cue ball does not have to go in last, but the 9 ball must pass in front of the cue ball. Decision of the table judge is final. No balls may be disturbed except the ball being struck. It is recommended that the player use object balls in numerical order. Players selecting this shot will be required to supply the cue stick butt.

Discipline 2 – Shot 5c – 10 points

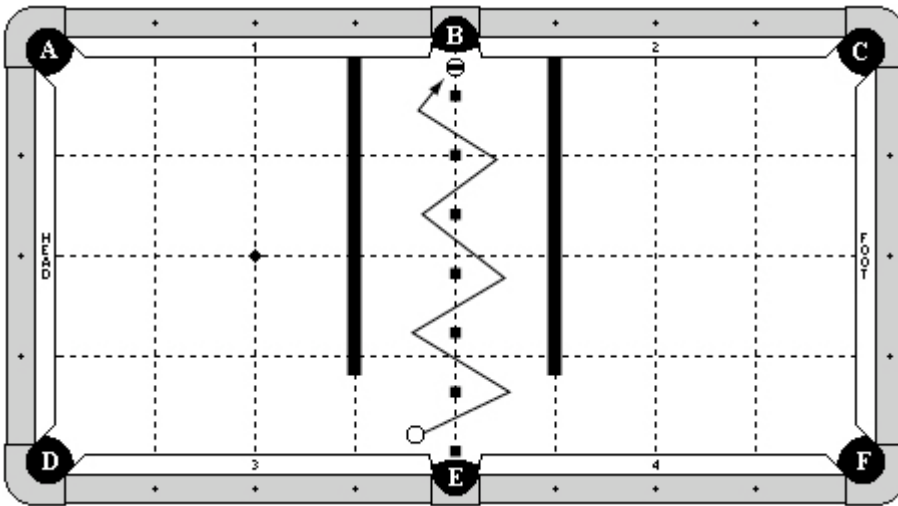

Cue Ball

In hand between first two chinks.

Object Balls

An object ball is hanging in pocket 'B'.

Props

Two jump cues are placed on the third diamond lines, frozen to cushions 1 and 2.

Seven pieces of chalk are placed along the centerline. The first piece is even with the cut of pocket 'E'. Subsequent pieces are three ball gaps away from the previous piece.

Objective

With one cue stick, volley the CB one-handed back and forth between the chinks. The last hit shoots the CB into OB pocketing the OB in pocket 'B'.

Special Notes

Players may use 2 cue butts or 2 cue shafts in lieu of 2 jump cues, but must place them the same. The chinks, jump cues and / or cue butts and / or cue shafts may not be contacted by any means until the OB is pocketed.

The moving cue ball may not cross the 3rd diamond line extensions created by the jump cues, cue butts, or cue shafts prior to entering the channel created by them. Trailing edge of the cue ball will be used to determine this. Decision of the table judge is final.

The cue ball may not come to a stop until OB is pocketed.

Players may use either or both hands, but all hits must be done one-handed, jacked up.

DISCIPLINE

3

DRAW SHOTS

Discipline 3 – Shot 1a – 6 points

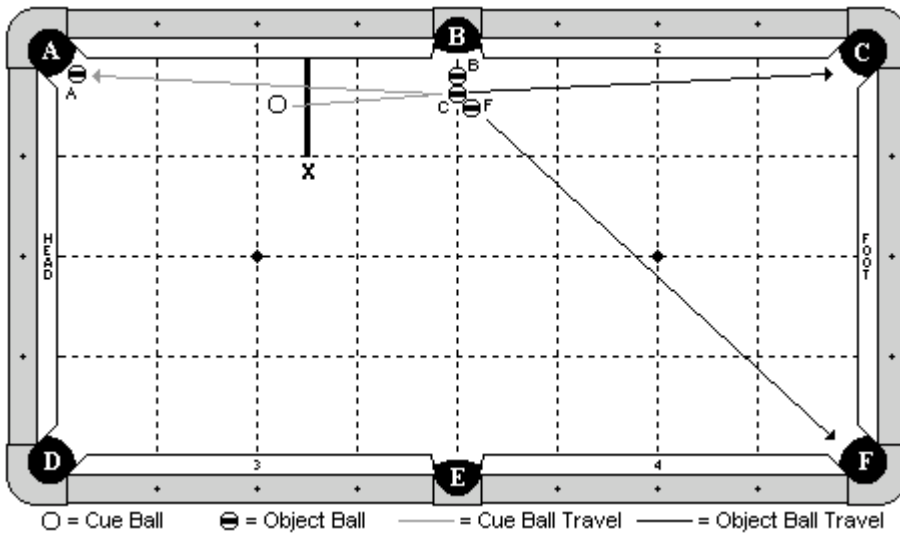

Cue Ball

In hand, behind the $2\frac{1}{2}$ diamond line as indicated by the diagram.

Object Balls

3 ball cluster is adjustable and near pocket 'B' as diagrammed. 'A' ball is hanging near pocket 'A'

Objective

Shoot the cue ball into the middle ball of the cluster. The three balls will go as designated by pocket letter. The cue ball will draw back and make 'A' ball.

Special Notes

None

Discipline 3 – Shot 1b – 6 points

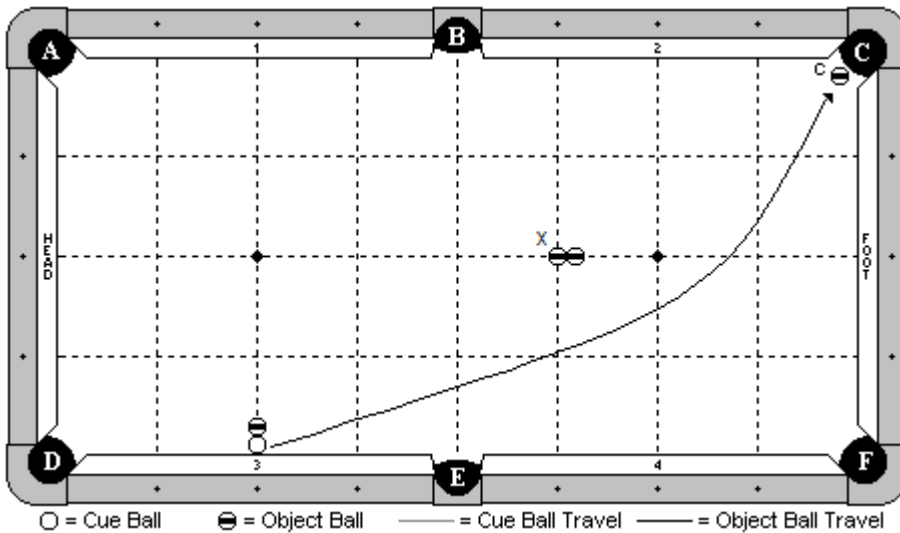

Cue Ball

Frozen to the cushion at the 2nd diamond.

Object Balls

'C' ball is hanging as diagrammed. A blocker ball is frozen to the cue ball on the 2nd diamond line. Two blocker balls are placed frozen on the long center line of the table, with the ball marked 'X' on the diamond intersection line as indicated by the diagram.

Objective

Shoot the cue ball into cushion 3, causing it to escape. The cue ball will curve/draw around the blocker balls and make 'C' ball.

Special Notes

The three blocker balls may not move by any means until after 'C' ball has been made.

Discipline 3 – Shot 1c – 6 points

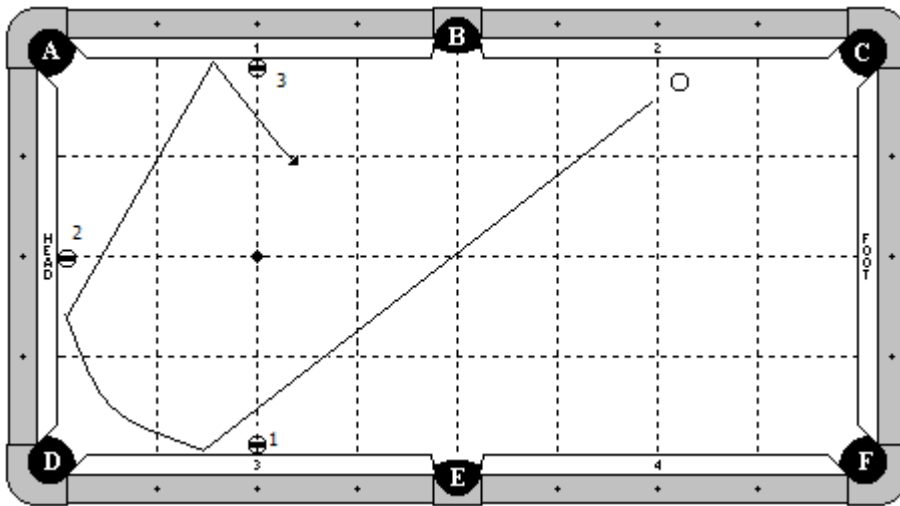

Cue Ball

In hand behind the foot string.

Object Balls

Three object balls frozen to the cushion at the diamond lines as diagrammed.

Objective

Shoot the cue ball three cushions as diagrammed. The cue ball must hit cushion 3 between the 1 ball and pocket 'D'. The cue ball must hit the head cushion between the 2 ball and pocket 'D'.

The cue ball must hit cushion 1 between the 3 ball and pocket 'A'.

Special Notes

The blocker balls may not be touched by any means. The trailing edge of the cue ball must pass the 2nd diamond line after hitting cushion 1 (the third rail).

Discipline 3 – Shot 2a – 7 points

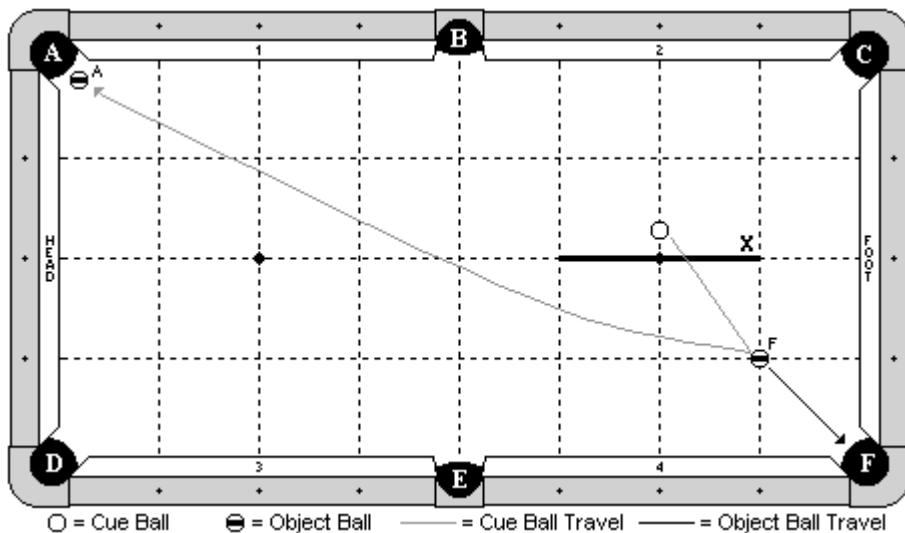

Cue Ball

In hand behind 'X' line.

Object Balls

'F' ball on the 1-1 diamond intersection line. 'A' ball is hanging near pocket 'A'.

Objective

Shoot the cue ball to make 'F' ball in pocket 'F'. The cue ball will draw back and make 'A' ball.

Special Notes

The cue ball may contact cushion 1 or the head cushion, but no other, prior to pocketing 'A' ball.

Discipline 3 – Shot 2b – 7 points

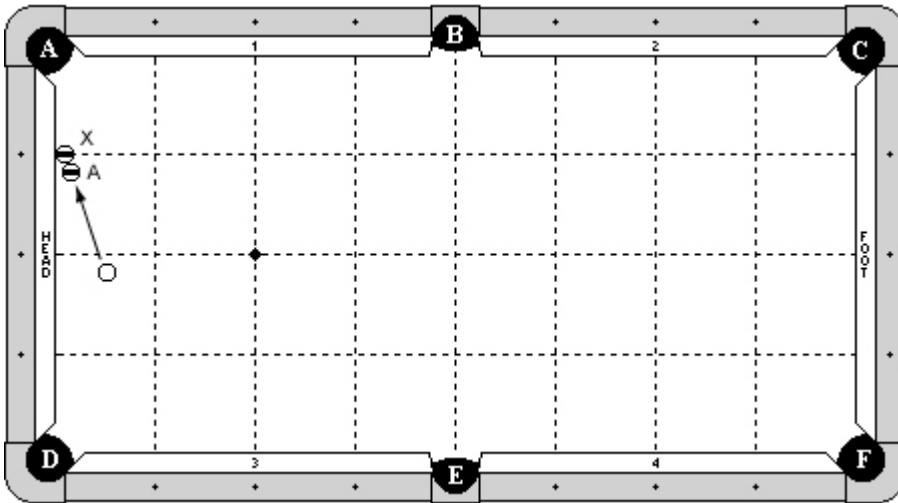

Cue Ball

In hand, behind long center line of table.

Object Balls

'X' ball is frozen to head cushion at the first diamond from pocket 'A'.

'A' ball is frozen to 'X' ball, as diagrammed.

Objective

Shoot cue ball in to 'A' ball. 'X' ball will bank away. 'A' ball will go in to pocket 'A'. After contact with 'A' ball, cue ball must draw back to contact rail 3 or 4 without hitting another cushion beforehand.

Special Notes

'A' ball may not be contacted by either 'X' ball or CB after the initial hit.

Discipline 3 – Shot 2c – 7 points

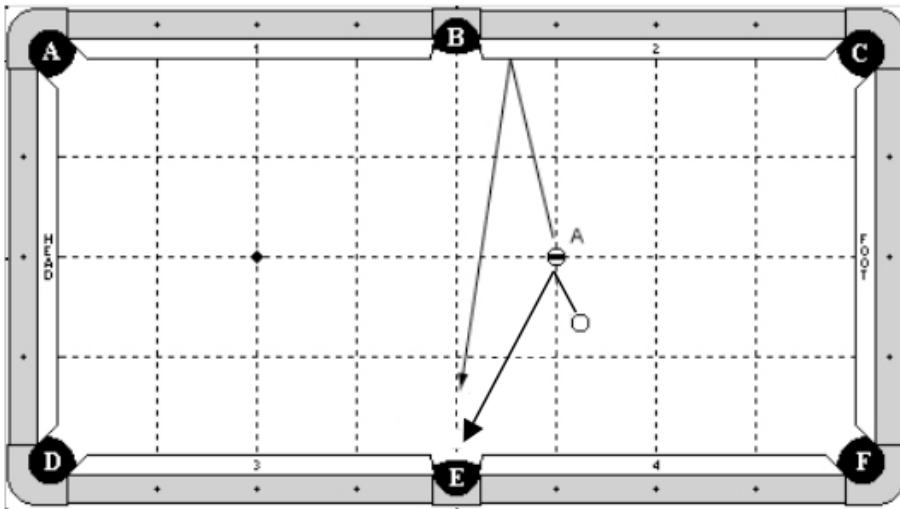

Cue Ball

In hand

Object Balls

'A' ball on the diamond intersection line as diagrammed.

Objective

Shoot the cue ball into 'A' ball, causing it to bank and make in pocket 'E'. The cue ball will draw back and go into pocket 'E'.

Special Notes

The cue ball must go into pocket 'E' first. Table judge decision is final.

Discipline 3 – Shot 3a – 8 points

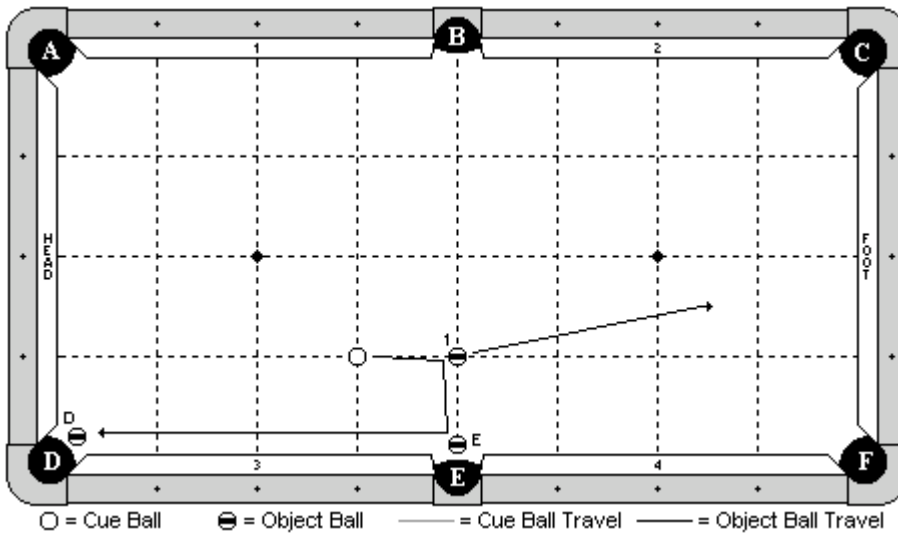

Cue Ball

In hand along the 3rd diamond line.

Object Balls

1 ball on the diamond intersection line as diagrammed. 'E' and 'D' balls are hanging near their respective pockets. 'E' ball may not be more than 1 ball's width from the pocket cut.

Objective

Shoot the cue ball into the 1 ball. The cue ball will carom over and make 'E' ball. It will then draw back and make 'D' ball.

Special Notes

The 1 ball doesn't have to be pocketed.

Discipline 3 – Shot 3b – 8 points

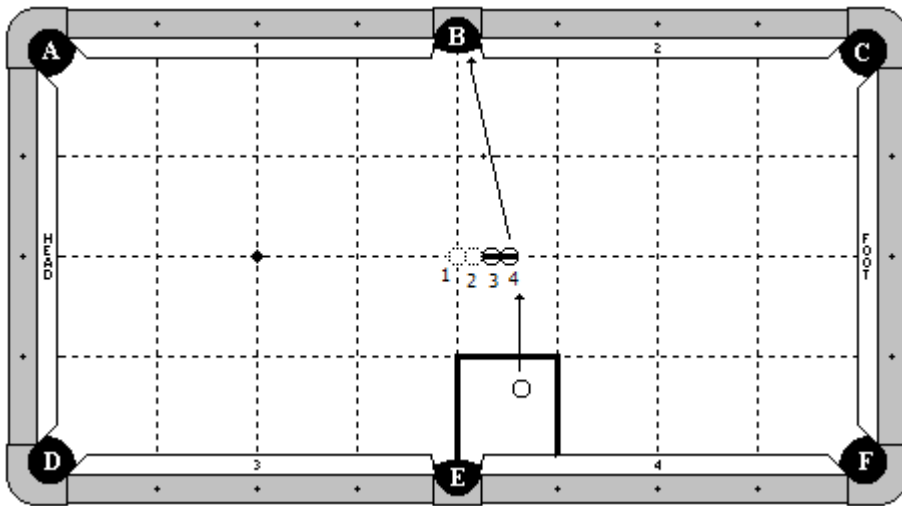

Cue Ball

In hand within the indicated zone.

Object Balls

Place 4 balls frozen in line along the center line of the table. Remove balls 1 and 2 and leave balls 3 and 4 in place.

Objective

Shoot the cue ball into the 4 ball. The 4 ball will go straight into pocket 'B'.

Special Notes

The balls must be exactly straight. Players are not allowed to rotate the balls and adjust the tangent line towards pocket 'B'.

Discipline 3 – Shot 3c – 8 points

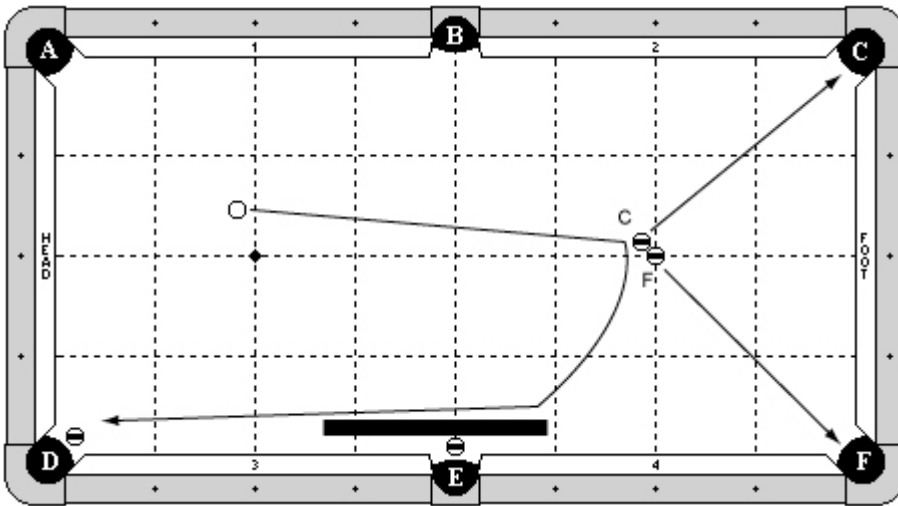

Cue Ball

In hand behind head string.

Object Balls

'F' ball on foot spot. 'C' ball in hand frozen to 'F' ball. An object ball is hanging in pocket 'E' and pocket 'D'. A cue stick butt is placed frozen to ball near pocket 'E'. The end of the butt must be more than 3 diamonds away from foot cushion.

Objective

Shoot cue ball in to 'C' ball causing 'C' ball to go in to pocket 'C' and 'F' ball to go in to pocket 'F'. Cue ball will draw back hitting the cue ball and pocketing the hanging ball in pocket 'E'. Cue ball will continue to draw down the rail to pocket the hanging ball in pocket 'D'.

Special Notes

None.

Discipline 3 – Shot 4a – 9 points

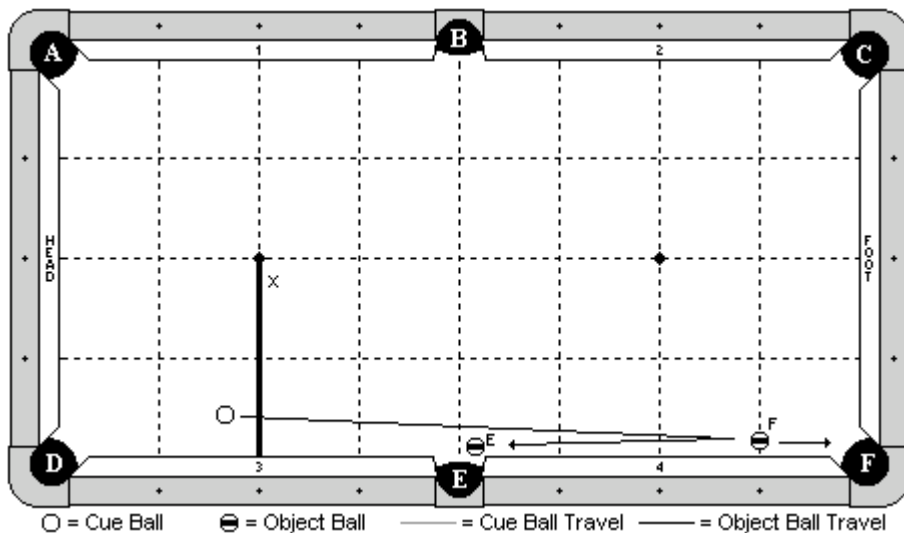

Cue Ball

In hand behind line 'X'.

Object Balls

'F' ball is in hand along the 1st diamond line. 'E' ball is hanging near pocket 'E' and is adjustable.

Objective

Shoot the cue ball and make 'F' ball in pocket 'F'. The cue ball will draw back and make 'E' ball.

Special Notes

The cue ball may contact cushion 4, but no other, until after 'E' ball is made.

Discipline 3 – Shot 4b – 9 points

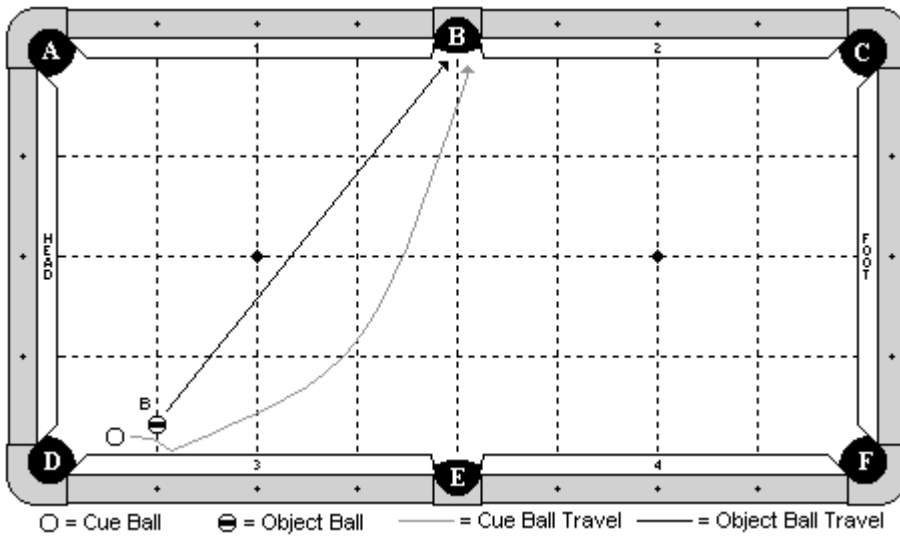

Cue Ball

In hand.

Object Balls

'B' ball is in hand along the 1st diamond line, but may be no more than 1 ball + 1 chalk's width from the cushion.

Objective

Shoot the cue ball into 'B' ball. The cue ball will curve around the rolling 'B' ball. Both balls will go into pocket 'B', cue ball first.

Special Notes

The balls may contact each other more than once. Close calls will be at the discretion of the table judge.

Discipline 3 – Shot 4c – 9 points

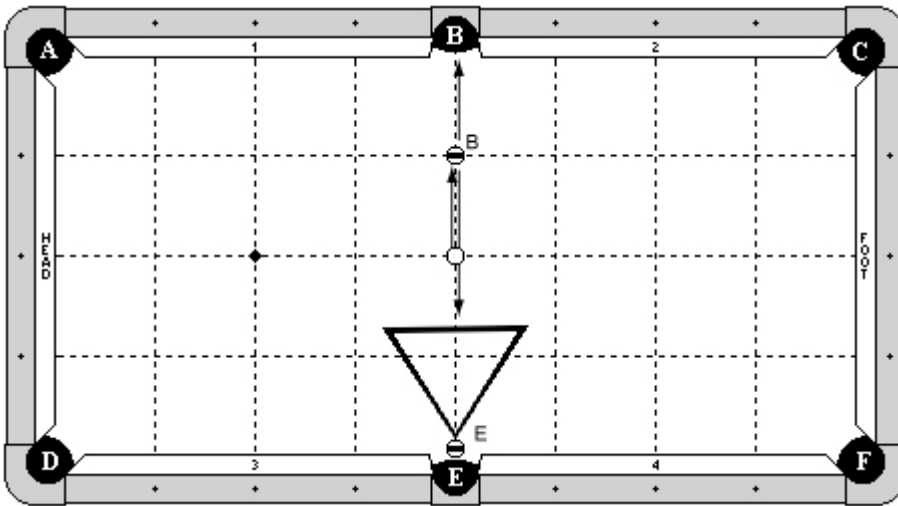

Cue Ball

On center spot.

Object Ball

'B' ball on center line, one diamond away from pocket 'B'.

'E' ball on center line, with back edge even with pocket cut or deeper.

A rack is frozen to 'E' ball as diagrammed.

Objective

Shoot the cue ball one-handed, jacked up, pocketing 'B' ball in pocket 'B' and drawing the cue ball back, hitting the rack and pocketing 'E' ball in pocket 'E'.

Special Notes

None.

Discipline 3 – Shot 5a – 10 points

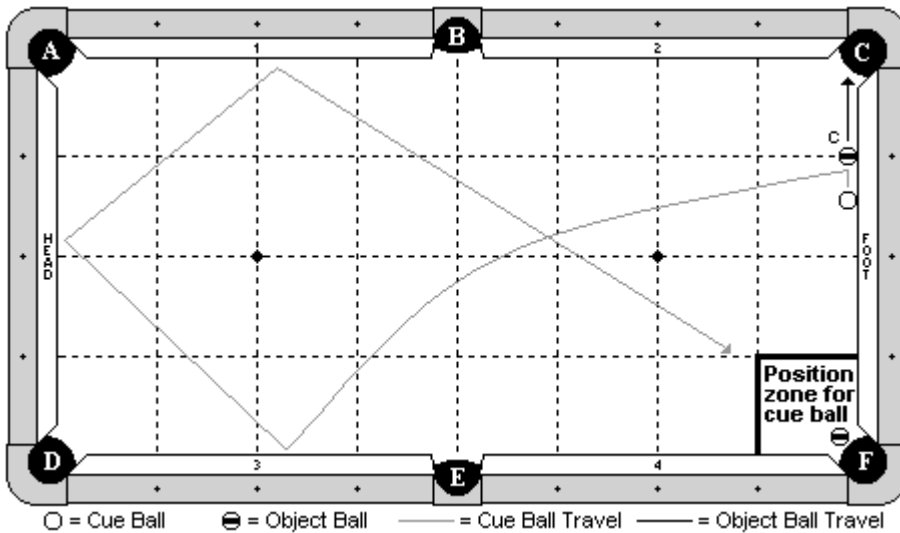

Cue Ball

In hand, frozen to the foot cushion, but must be at least 1 ball's width from the object ball.

Object Balls

'C' ball frozen to the foot cushion at the 1st diamond. A blocking ball is placed in front of pocket 'F' to prevent a scratch.

Objective

Shoot the cue ball and make 'C' ball. The cue ball will draw around the table as indicated, and come to rest inside the 1x1 diamond zone.

Special Notes

The cue ball may contact cushion 3 or 4 as the 1st cushion. The blocker ball does not have to be made. Scratch is not allowed. The cue ball may contact extra cushions near pocket 'F'.

Discipline 3 – Shot 5b – 10 points

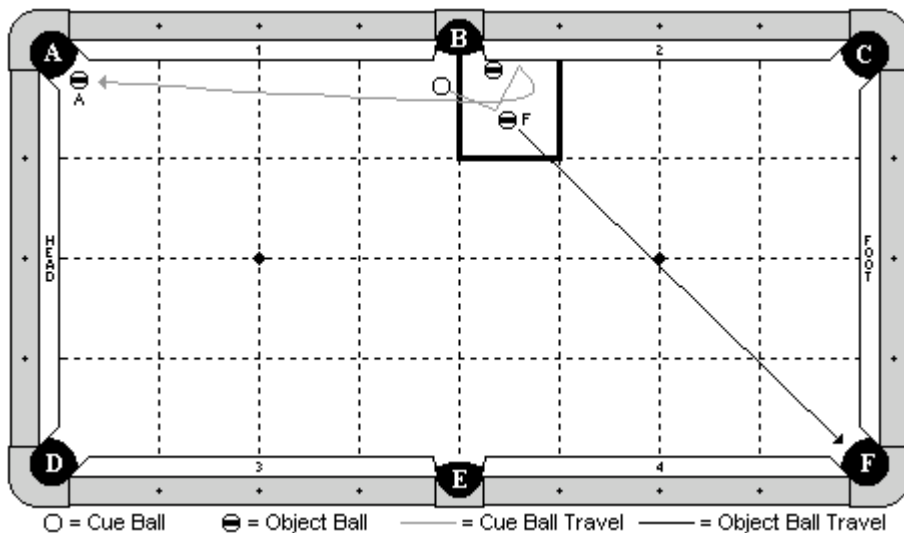

Cue Ball

In hand.

Object Balls

Blocker ball is frozen to cushion 2 with the edge aligned with the pocket point. 'F' ball is in hand within the indicated zone. 'A' ball is hanging near pocket 'A'.

Objective

Shoot the cue ball and make 'F' ball in pocket 'F'. The cue ball will carom into cushion 2, draw around the blocker ball, and make 'A' ball.

Special Notes

The blocker ball may not be touched by any means until after 'A' ball is made.

Discipline 3 – Shot 5c – 10 points

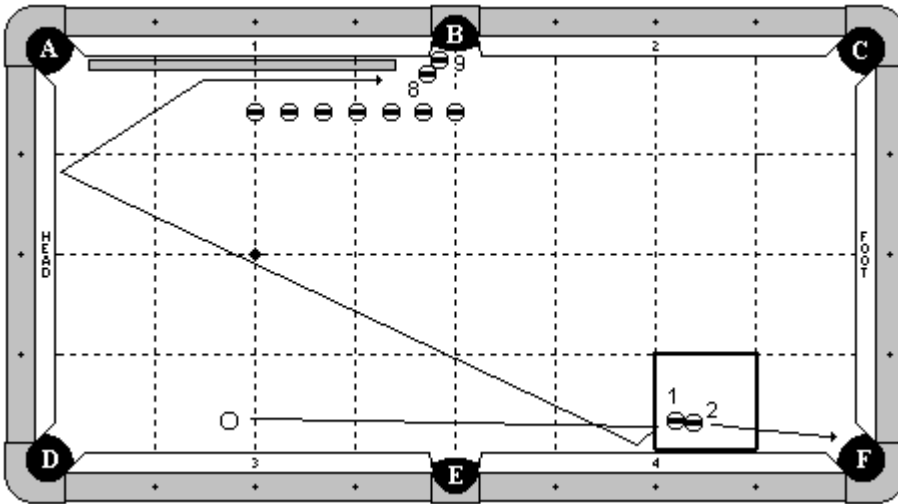

Cue Ball

In hand behind the head string.

Object Balls

The 1-2 combination is in hand within the indicated zone. The 8-9 combination is near pocket 'B' as diagrammed. 7 blocker balls are 3 ball's width off the cushion. The first ball is on the 2nd diamond line, the last ball is on the center line, and the others are evenly spaced between them.

A cue stick butt is frozen to cushion 1.

Objective

Shoot the cue ball and make the 2 ball in pocket 'F'. The cue ball will draw back as diagrammed, hit the cue stick, and make the 8-9 combination.

Special Notes

The cue ball does not need to hit cushion 4. It may draw straight back into the head cushion.

The blocker balls may not be disturbed by any means until after the cue ball hits the 8 ball. After the cue ball contacts the 1 ball for the first time, the 1 ball may not interfere with the shot.

Players selecting this shot will be required to supply the cue stick butt.

DISCIPLINE

4

FOLLOW SHOTS

Discipline 4 – Shot 1a – 6 points

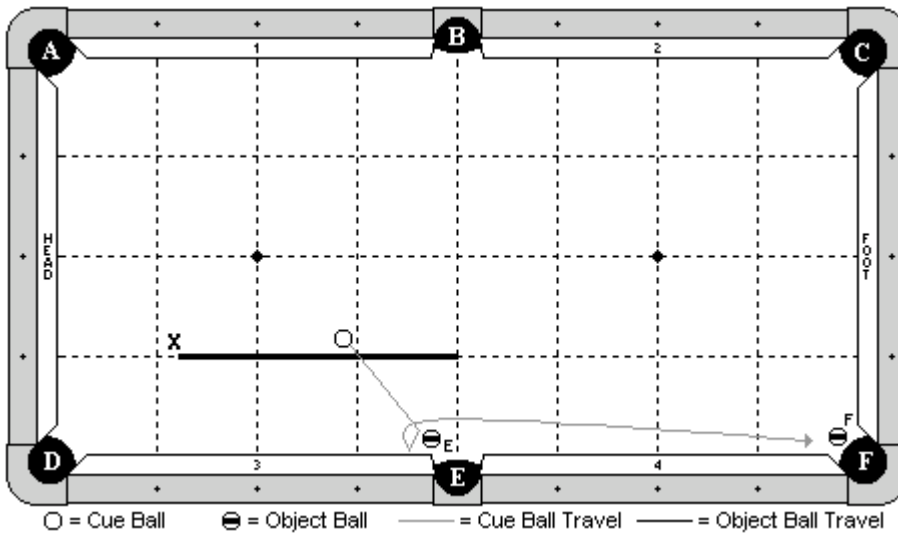

Cue Ball

In hand behind the 'X' line.

Object Balls

'E' ball is near pocket 'E' and adjustable. 'F' ball is hanging near pocket 'F'.

Objective

Shoot the cue ball and make 'E' ball. The cue ball will then contact cushion 3, and force follow forward to make 'F' ball.

Special Notes

The cue ball must contact ball 'E' prior to contacting cushion 3. The cue ball must contact cushion 3. It may not make 'E' ball and simply carom down the rail to make 'F' ball.

Discipline 4 – Shot 1b – 6 points

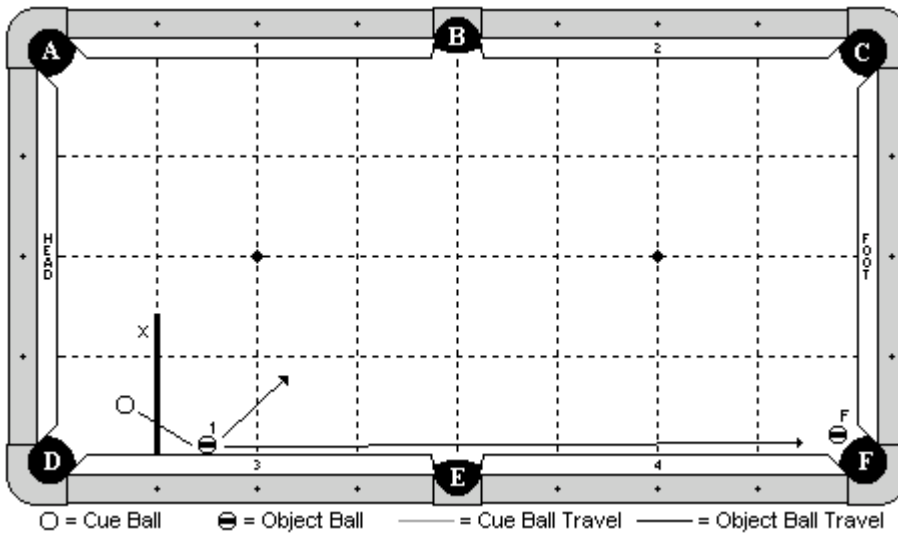

Cue Ball

In hand behind 'X' line.

Object Balls

The 1 ball is frozen to the cushion at 1 ½ diamonds. 'F' ball is hanging near pocket 'F'.

Objective

Shoot the cue ball into the 1 ball. The cue ball will force follow down the table and make 'F' ball.

Special Notes

This is not a carom shot. Players may not simply glance off the side of the 1 ball and roll down to make 'F' ball. Players must hit the 1 ball full (approximately) and force follow down the table. Decision of the table judge is final.

Discipline 4 – Shot 1c – 6 points

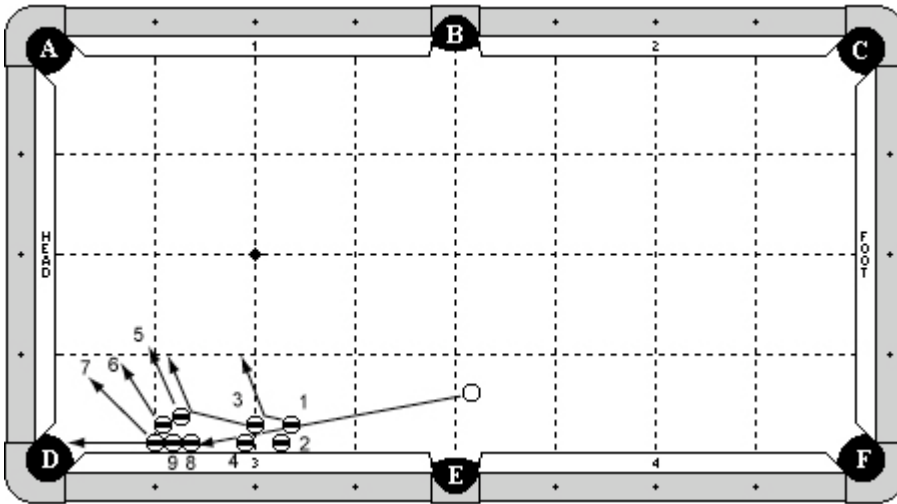

Cue Ball

In hand, behind short center line of table.

Object Balls

7 ball is frozen to cushion 3 at first diamond from pocket 'D'.

9 ball is frozen to 7 ball and cushion 3, as diagrammed.

8 ball is frozen to 9 ball and cushion 3, as diagrammed.

6 ball is frozen to 7 ball.

5 ball is frozen to 6 ball.

4 ball is frozen to cushion 3, at least two balls spacing from 8 ball.

3 ball is frozen to 4 ball.

2 ball is frozen to cushion 3 at least one ball spacing from 4 ball.

1 ball is frozen to 2 ball.

Objective

Shoot cue ball in to 1 ball. The 1 ball will bank the 2 ball out of the way and carom in to the 3 ball. The 3 ball will bank the 4 ball out of the way and carom in to the 5 ball. The 5, 6, and 7 balls will all clear out of the way. The cue ball will follow forward, hitting the 8 ball and causing the 9 ball to go in pocket 'D'.

Special Notes

The 9 ball may not be contacted by any balls on its way to the pocket.

Discipline 4 – Shot 2a – 7 points

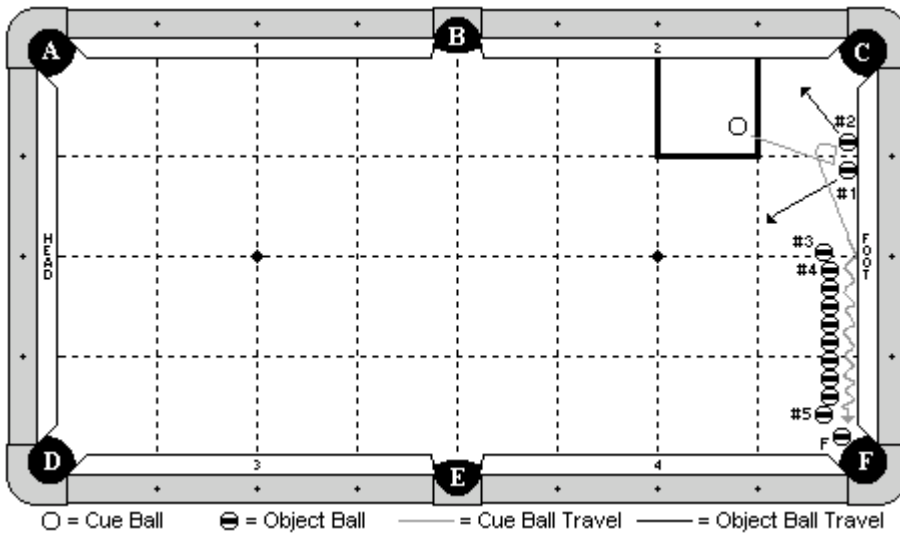

Cue Ball

In hand within the indicated zone.

Object Balls

Balls 1 & 2 are frozen to the foot cushion and centered around the 1st diamond. 'F' ball is hanging near pocket 'F'. A row of 10 balls is approximately 1 ball's width off the cushion, but this spacing may be adjusted by the player. The row must be straight (parallel to the foot cushion), with the option of adjusting balls 3, 4, and/or 5. If this option is used, those balls must still remain frozen to the others in the line.

Objective

Shoot the cue ball to ball # 1, then carom into ball # 2, and then travel between the row of balls and the cushion. The cue ball will hit at least 4 object balls, and then go on to make 'F' ball.

Special Notes

The cue ball must hit ball 1 first, then ball 2. The cue ball must make 'F' ball. It may not be made by an object ball. If the cue ball comes to a stop and is later helped by another ball coming in contact with the row of balls or the cue ball, the shot is no good. The cue ball must make 'F' ball on its own. Decision of the table judge is final.

Discipline 4 – Shot 2b – 7 points

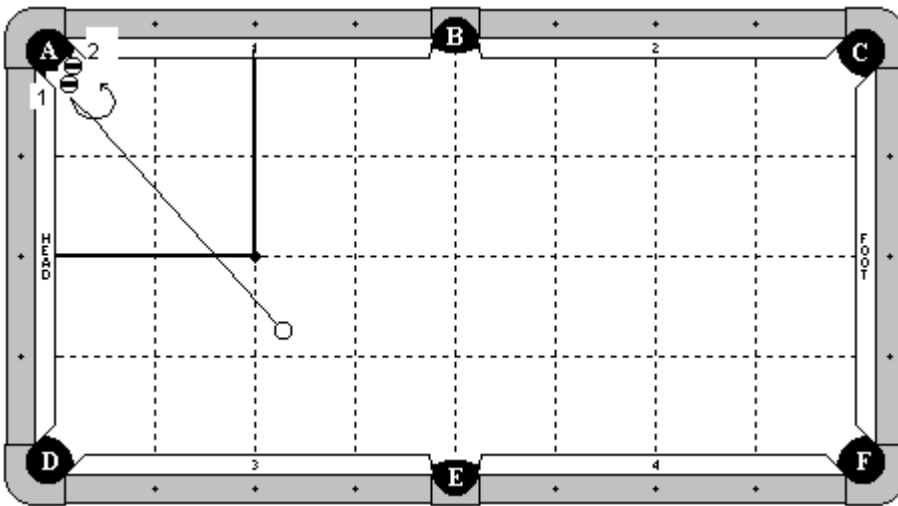

Cue Ball

In hand outside the indicated zone.

Object Balls

The 1 ball is a special stacking ball. The 2 ball is balanced on top of it.

Objective

Shoot the cue ball into the 1 ball, making it in pocket 'A'. The 2 ball will fall in place. The cue ball must hit either the long rail or the head rail, and then it will follow forward and make the 2 ball.

Special Notes

The referee will stand close to make sure the cue ball hits a cushion before making the 2 ball. Decision of the referee is final.

Discipline 4 – Shot 2c – 7 points

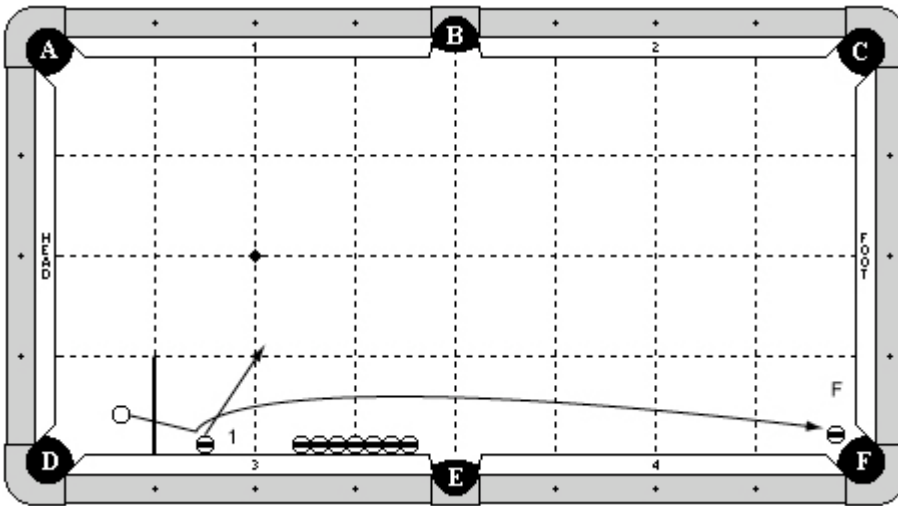

Cue Ball

In hand behind first diamond on cushion '3'.

Object Balls

'1' ball frozen to cushion 3 at 1 ½ diamonds from pocket 'D'.

'F' ball hanging in pocket 'F'.

A row of 7 object balls is frozen to cushion 3, centered on the 3rd diamond.

Objective

Shoot cue ball into 1 ball. The cue ball will curve around the blocking balls and make 'F' ball in pocket 'F'.

Special Notes

'F' ball must be made by the cue ball.

Blocking balls may not be contacted by any means until after 'F' ball is made.

Cue ball may contact cushion 3 before passing blocker balls.

Discipline 4 – Shot 3a – 8 points

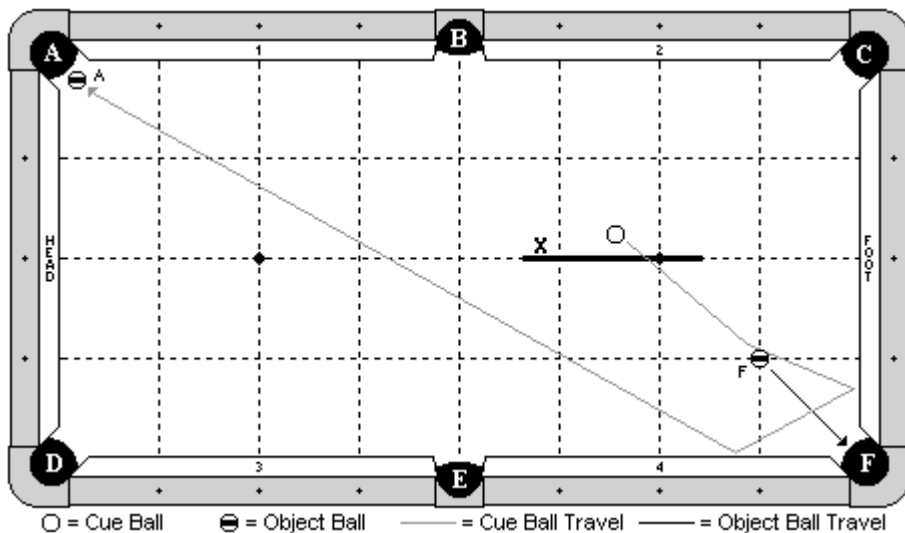

Cue Ball

In hand behind the indicated line.

Object Balls

'F' ball on the 1-1 diamond intersection line. 'A' ball is hanging near pocket 'A'.

Objective

Shoot the cue ball and make 'F' ball in pocket 'F'. The cue ball will follow forward 2 cushions as diagrammed, and make 'A' ball in pocket 'A'.

Special Notes

None

Discipline 4 – Shot 3b – 8 points

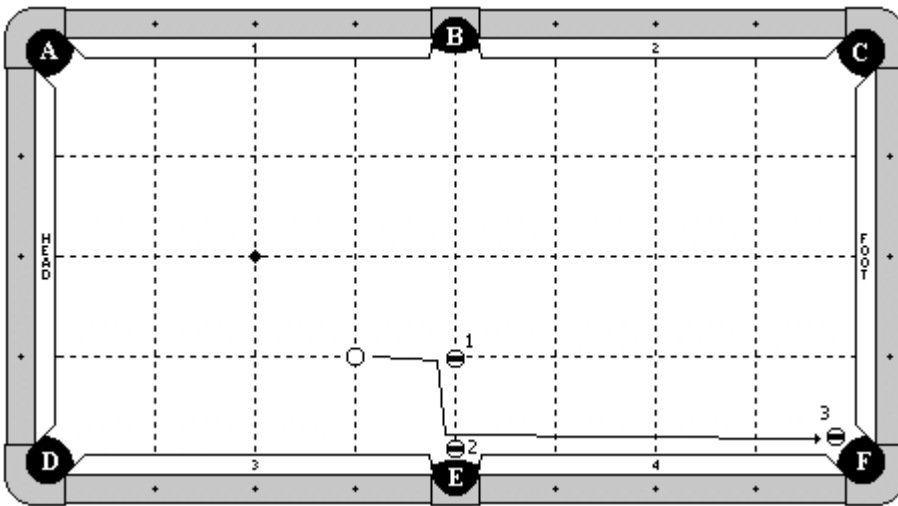

Cue Ball

In hand along the 3rd diamond line.

Object Balls

1 ball is on the diamond intersection line as diagrammed. 2 & 3 balls are hanging near their respective pockets, no more than one ball width from the cut of the pocket.

Objective

Shoot the cue ball into the 1 ball. The cue ball will carom over and make the 2 ball, and then follow down to make the 3 ball.

Special Notes

The 1 ball does not have to be made. The 1 ball may not interfere with the shot until after the 3 ball is made.

Discipline 4 – Shot 3c – 8 points

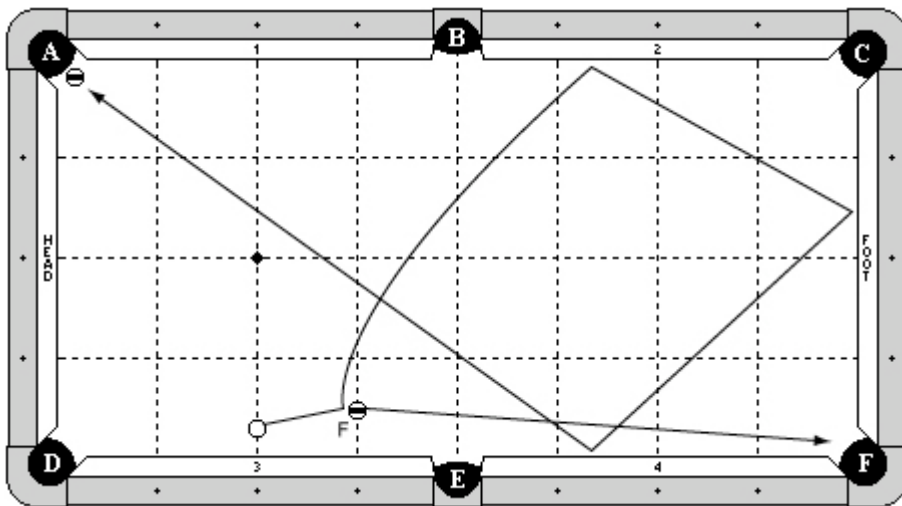

Cue Ball

In hand, but must be at least 1 chalk's width from F ball

Object Balls

'F' ball exactly two balls width from cushion 3 on third diamond line.

An object ball is hanging in pocket 'A'.

Objective

Shoot cue ball in to 'F' ball. 'F' ball will go in to pocket 'F'. Cue ball will contact cushion 2, foot cushion, and cushion 4 and make hanging ball in pocket 'A'.

Special Notes

Cue ball may contact extra cushions by pocket 'A'.

Discipline 4 – Shot 4a – 9 points

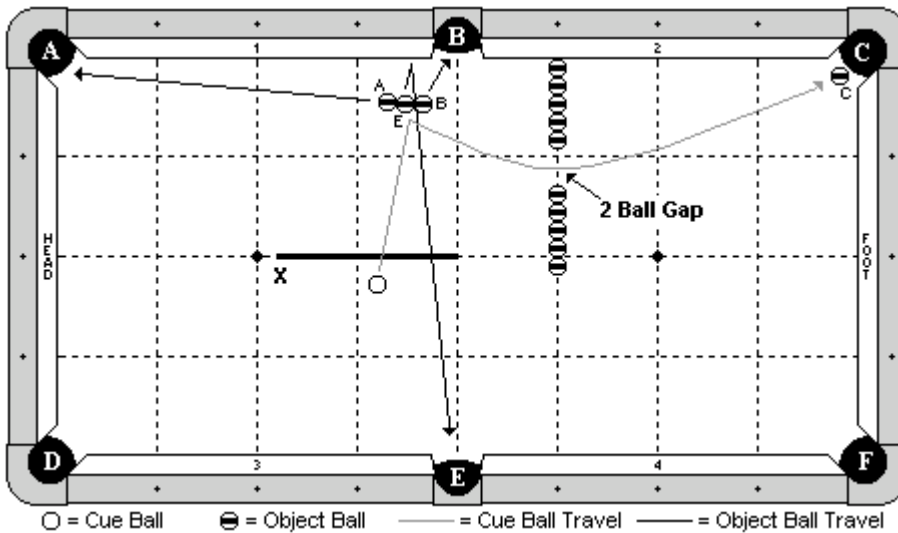

Cue Ball

In hand behind the indicated line.

Object Balls

'B' and 'E' balls are frozen and exactly 2 ball's width off the cushion, and adjustable left or right. 'A' ball is adjustable and frozen to 'E' ball. 'C' ball is hanging near pocket 'C'. A line of 10 object balls are along the 3rd diamond line. A gap of 2 ball's width is between the first 5 balls and the last 5 balls.

Objective

Shoot the cue ball and make the three balls as pocket letter designates. The cue ball will travel the indicated path through the gap, and follow forward to make 'C' ball.

Special Notes

The blocking balls may not be touched by any means until after 'C' ball is made.

Discipline 4 – Shot 4b – 9 points

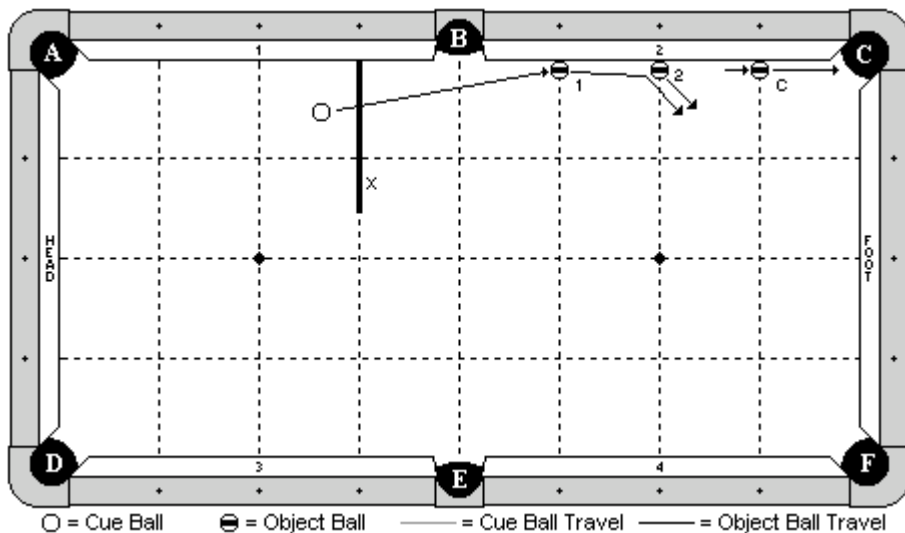

Cue Ball

In hand behind the indicated line.

Object Balls

1 and 2 balls are on their indicated diamond lines and frozen to the cushion. 'C' ball is on the 1st diamond and adjustable along that line.

Objective

Shoot the cue ball into the 1 ball. The 1 ball will hit the 2 ball and both will clear. The cue ball will follow forward and make 'C' ball.

Special Notes

'C' ball may not be contacted by any ball other than the cue ball.

Discipline 4 – Shot 4c – 9 points

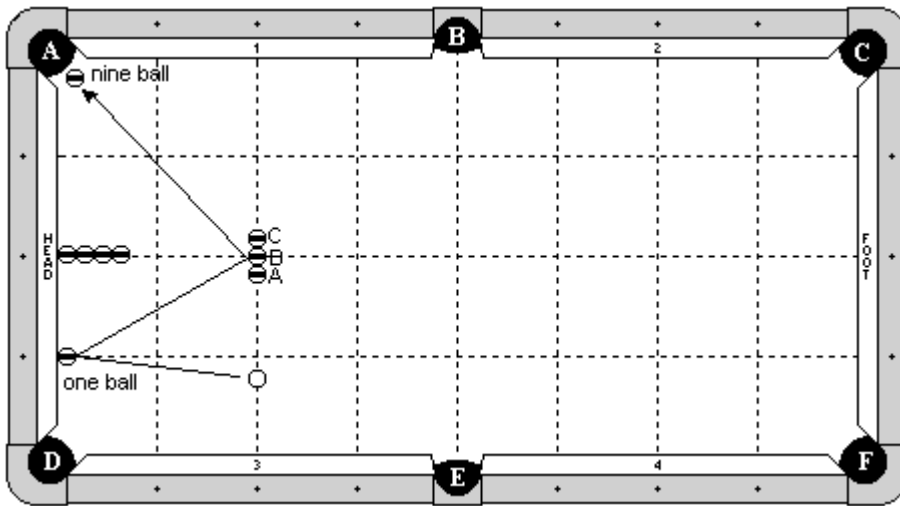

Cue Ball

In hand along the 2nd diamond line.

Object Balls

1 ball frozen to the head cushion at the 1st diamond. 'A', 'B', and 'C' balls are frozen in line along the head string with 'B' ball on the head spot. 4 blocker balls are along the 2nd diamond line with the first ball frozen to the cushion. The 9 ball is hanging near pocket 'A',

Objective

Shoot the cue ball into the 1 ball. The cue ball will double kiss back into the line of three balls (A,B,C), and then follow forward to make the 9 ball.

Special Notes

The cue ball may not contact any cushions except possibly the head cushion or cushion 1 near pocket 'A'. The cue ball may contact any combination of 'A', 'B', 'C' balls. The 4 blocker balls may not be contacted by the cue ball until after the 9 ball is made.

Discipline 4 – Shot 5a – 10 points

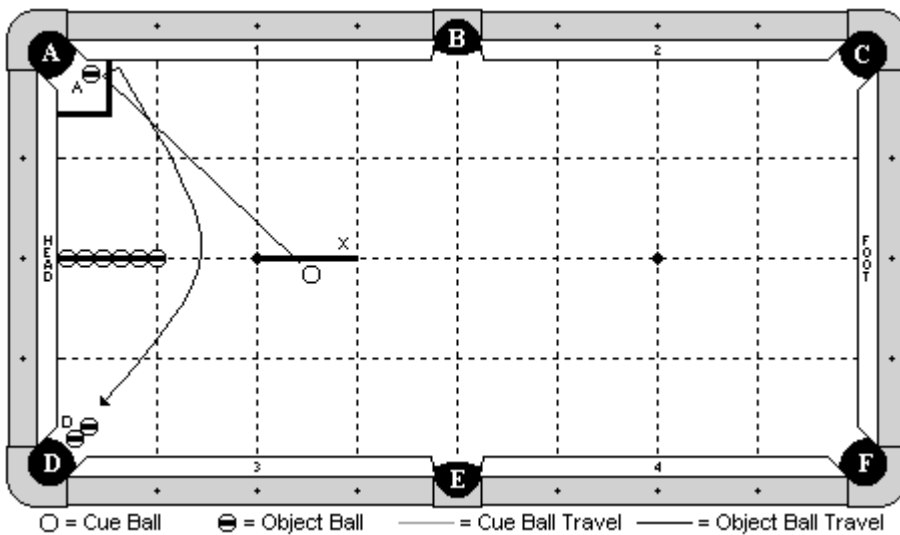

Cue Ball

In hand behind the indicated line.

Object Balls

'A' ball is near pocket 'A' and adjustable, but the back edge of the ball may not pass the pocket point on cushion 1. 'D' ball and another ball form a combination near pocket 'D'. The center of 'D' ball may not be further out than the pocket points. 6 blocker balls are frozen in line along the middle diamond.

Objective

Shoot the cue ball into 'A' ball, making it in 'A' pocket. The cue ball will hit cushion 1, curve around the blocker balls, and make the combination.

Special Notes

The blocker balls may not be hit by any means until after 'D' ball is made.

Discipline 4 – Shot 5b – 10 points

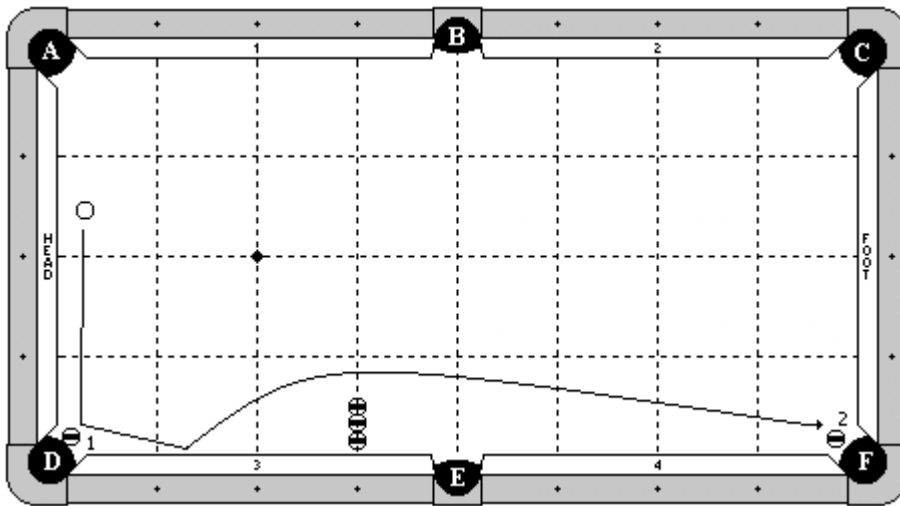

Cue Ball

In hand behind the long center line of the table.

Object Balls

1 ball is hanging near pocket 'D' and adjustable. 2 ball is hanging near pocket 'F'. Three blocker balls are frozen in line along the 3rd diamond.

Objective

Shoot the cue ball into the 1 ball, making it in pocket 'D'. The cue ball will hit cushion 3, bounce out and around the three blocker balls, and make the 2 ball.

Special Notes

The blocker balls may not be hit by any means until after the 2 ball is made.

Discipline 4 – Shot 5c – 10 points

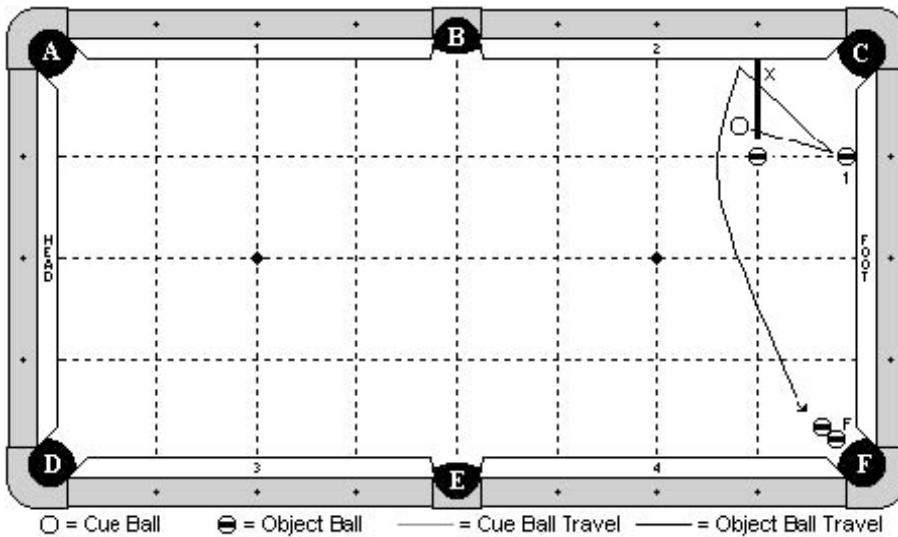

Cue Ball

In hand behind line 'X', as diagrammed.

Object Balls

Object ball '1' is frozen to the foot cushion at 1 diamond segment.

Blocking ball is placed at the 1x1 diamond intersection.

Two ball combination is hanging by pocket 'F'.

Objective

Shoot cue ball into 1 ball. Cue ball will double kiss back off cushion 2 and curve around blocking ball, hit the two ball combination, and pocket 'F' ball.

Special Notes

Cue ball may not contact foot cushion before contacting cushion 2.

The blocking ball may not be contact by any means until after 'F' ball is made.

Extra contacts between the 1 ball and cue ball are not allowed.

DISCIPLINE

5

BANK / KICK SHOTS

Discipline 5 – Shot 1a – 6 points

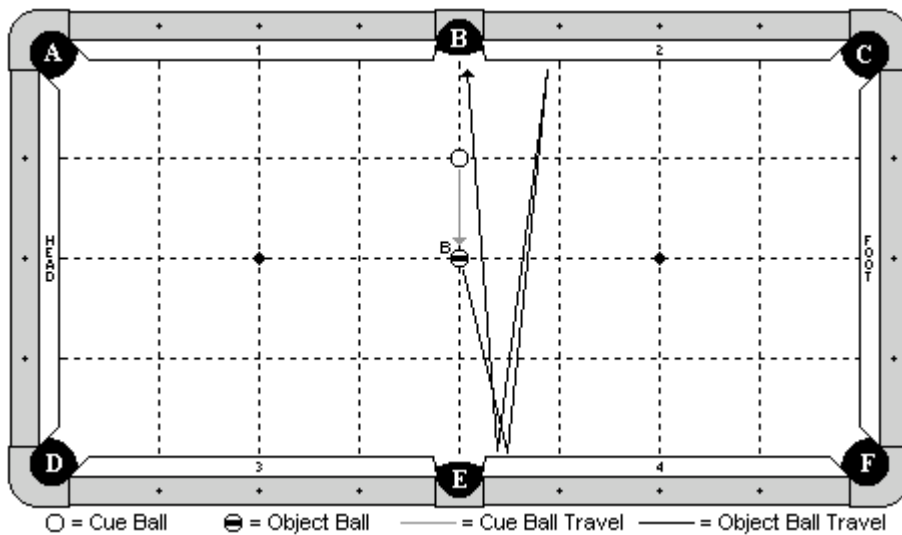

Cue Ball

On the diamond intersection line as diagrammed.

Object Balls

'B' ball on the exact center spot of the table.

Objective

Shoot the cue ball into 'B' ball. 'B' ball will bank three cushions as diagrammed (cushion 4, cushion 2, cushion 4), and go into pocket 'B'.

Special Notes

None

Discipline 5 – Shot 1b – 6 points

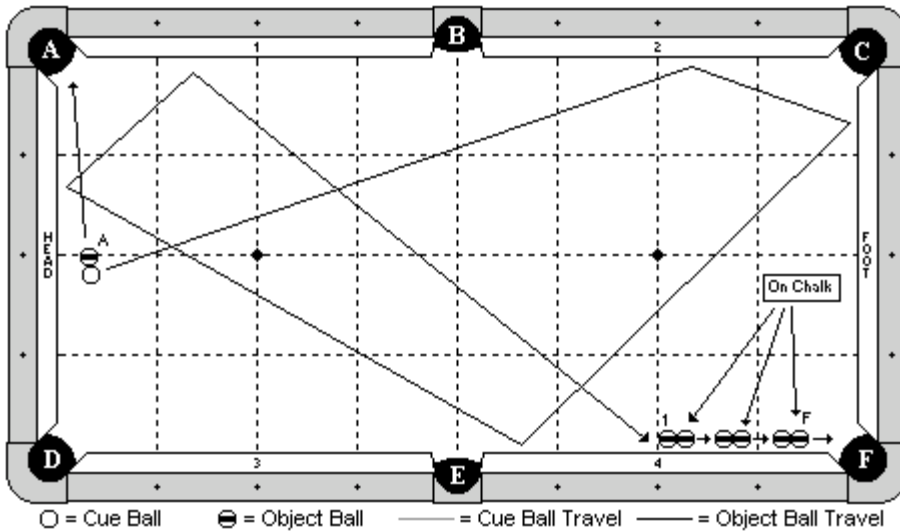

Cue Ball

In hand, frozen to 'A' ball.

Object Balls

'A' ball in hand along the long center line. 6 balls are lined up near pocket 'F'. The first ball (left most ball in the diagram) in each group is on the table, and the other ball is on top of a new chalk cube (well up). Each group of balls must be at least 1 ball's width apart. The entire line may not be more than 1 chalk's width off the cushion. The last ball ('F') may not have its forward edge past the pocket point.

Objective

Shoot the cue ball making 'A' ball in pocket 'A'. The cue ball will travel 5 cushions as diagrammed, hit the 1 ball (the first ball in the line), and start a chain reaction. Each ball on the chalk will fall and hit the next ball in line, until the 'F' ball goes into pocket 'F'.

Special Notes

The cue ball may contact an extra cushion near the 1 ball. The cue ball must contact the 1 ball first. The cue ball may contact the ball on the chalk that is frozen to the 1 ball, but it must contact the 1 ball first.

Discipline 5 – Shot 1c – 6 points

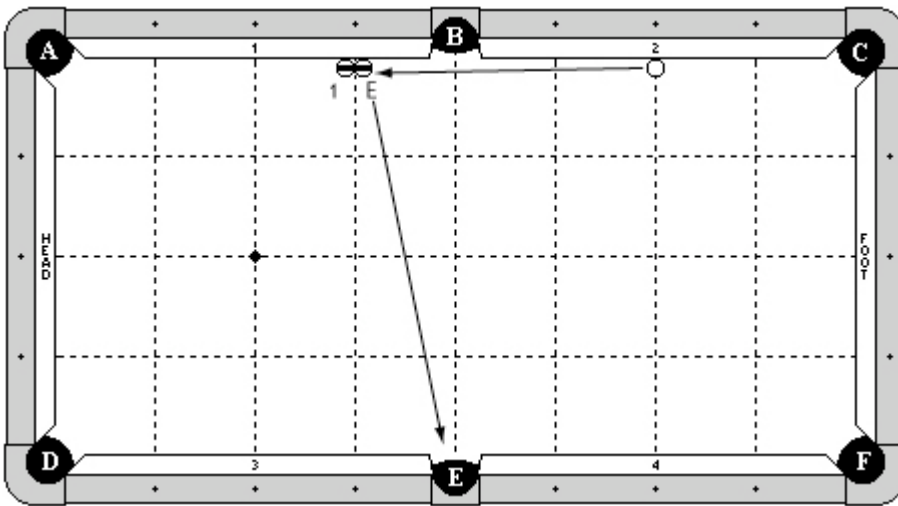

Cue Ball

Frozen to cushion 2 on second diamond line.

Object Balls

1 ball and 'E' ball are frozen to each other and to cushion 1. They are split on the 3rd diamond.

Objective

Shoot cue ball in to 'E' ball causing 'E' ball to bank in to pocket 'E'.

Special Notes

'E' ball may not be contacted again after the initial hit.

Discipline 5 – Shot 2a – 7 points

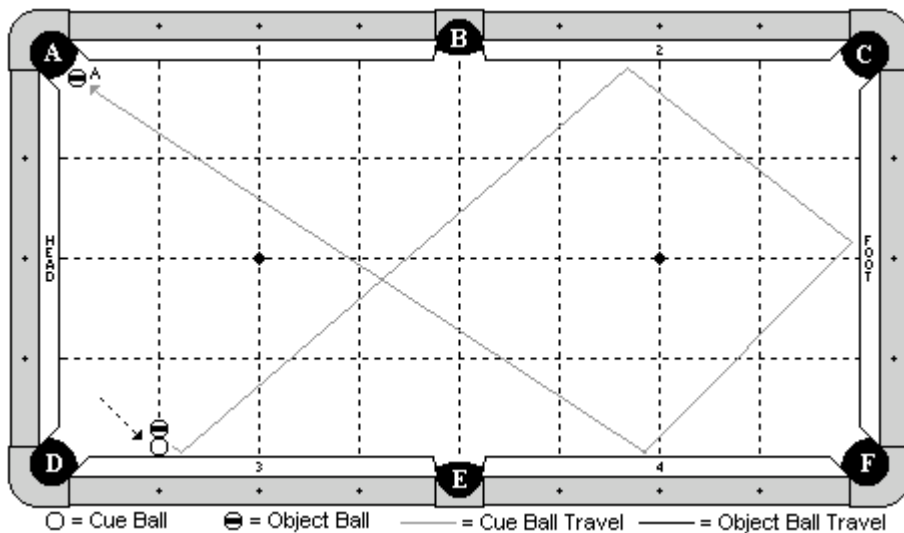

Cue Ball

Frozen to the cushion at the 1st diamond.

Object Balls

'A' ball hanging near pocket 'A'. A blocker ball is along the 1st diamond and frozen to the cue ball.

Objective

Shoot the cue ball in the direction of the arrow, causing it to escape out. The cue ball will travel around the table as diagrammed, and make 'A' ball.

Special Notes

The blocker ball may not move by any means until after 'A' ball is made.

Discipline 5 – Shot 2b – 7 points

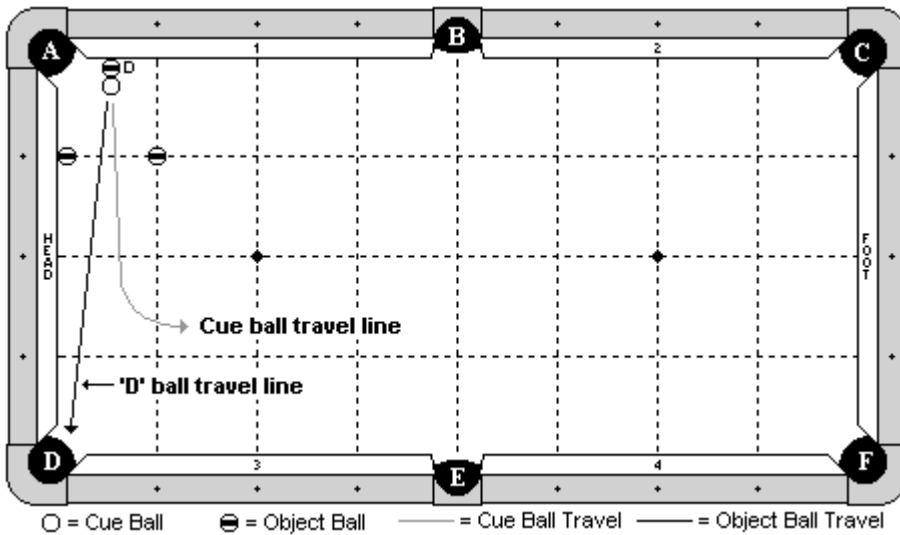

Cue Ball

Along the $\frac{1}{2}$ diamond line, frozen to 'D' ball.

Object Balls

'D' ball along the $\frac{1}{2}$ diamond line, frozen to the cushion. A blocker ball is on the 1st diamond line, frozen to the head cushion. Another blocker ball is on the 1-1 diamond intersection line.

Objective

Shoot the cue ball and cause 'D' ball to bank back into pocket 'D'. The cue ball must come out between the two blocker balls.

Special Notes

The blocker balls may not be contacted by any means until after 'D' ball is made. The cue ball and 'D' ball may contact each other multiple times.

Discipline 5 – Shot 2c – 7 points

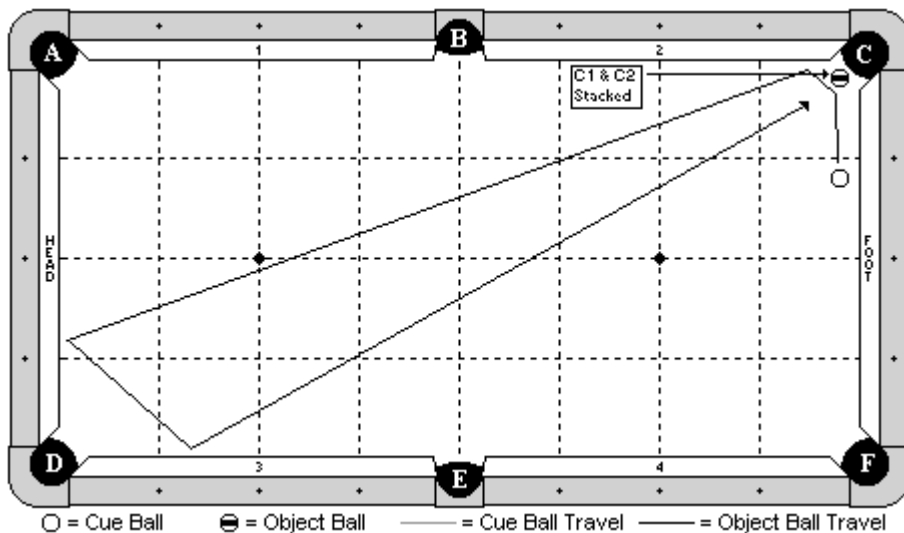

Cue Ball

In hand.

Object Balls

A stacker ball is hanging near pocket 'C'. An object ball is balanced on top of it.

Objective

Shoot the cue ball into the stacker ball, making it in pocket 'C' and causing the object ball to fall in place. The cue ball will travel three cushions as diagrammed, and make the object ball in pocket 'C'.

Special Notes

None

Discipline 5 – Shot 3a – 8 points

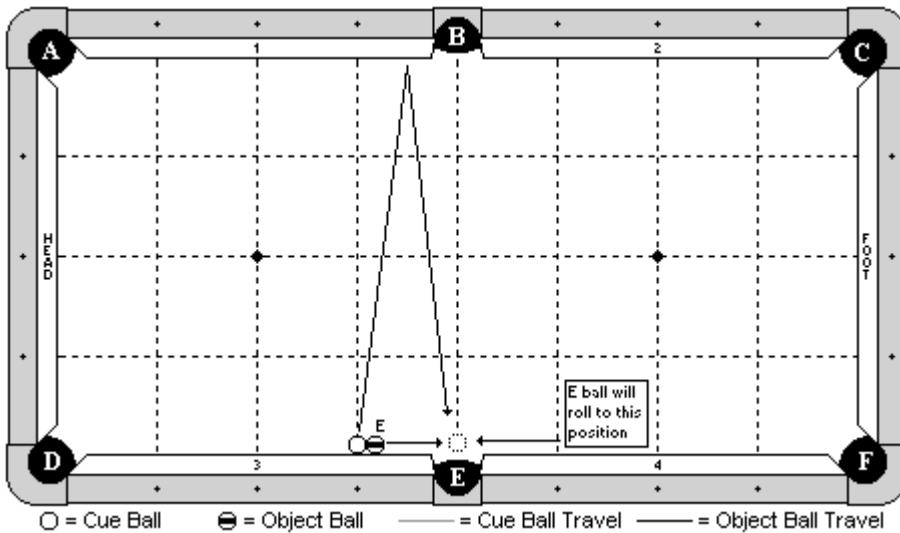

Cue Ball

Frozen to the cushion at the 3rd diamond.

Object Balls

'E' ball frozen to the cushion and to the cue ball.

Objective

Shoot the cue ball to bank one rail as diagrammed. 'E' ball will roll in front of pocket 'E'. The cue ball will bank back into 'E' ball and make it in pocket 'E'.

Special Notes

None

Discipline 5 – Shot 3b – 8 points

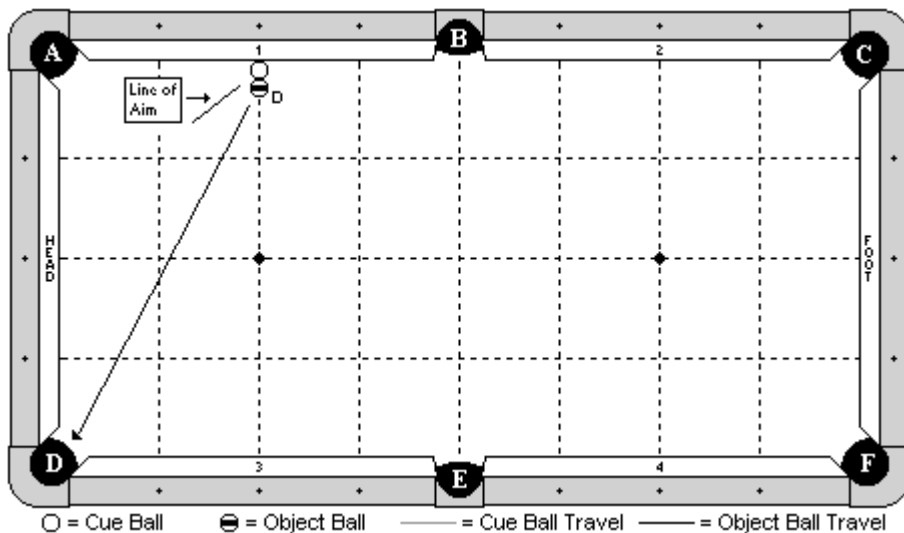

Cue Ball

Frozen to the cushion at the 2nd diamond.

Object Balls

'D' ball along the 2nd diamond, frozen to the cue ball.

Objective

Shoot the cue ball into the cushion along the line of aim indicated by the diagram. The cue ball will back cue 'D' ball into 'D' pocket.

Special Notes

None

Discipline 5 – Shot 3c – 8 points

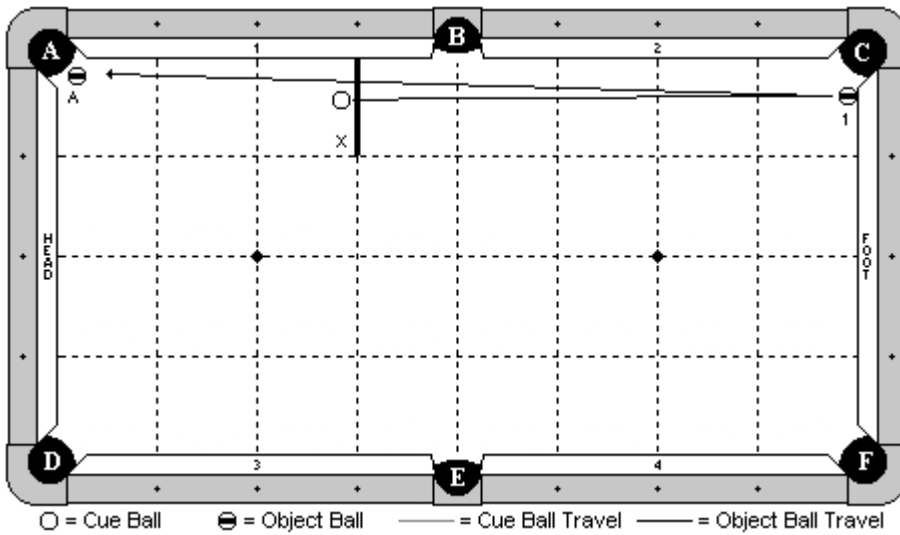

Cue Ball

In hand behind the indicated line.

Object Balls

1 ball frozen to the foot cushion, with the edge aligned with the pocket point. 'A' ball is hanging near pocket 'A'.

Objective

Shoot the cue ball into the 1 ball, causing it to double kiss back and make 'A' ball.

Special Notes

The cue ball may contact cushion 1 or the head cushion, but no other, until after 'A' ball is made.

Discipline 5 – Shot 4a – 9 points

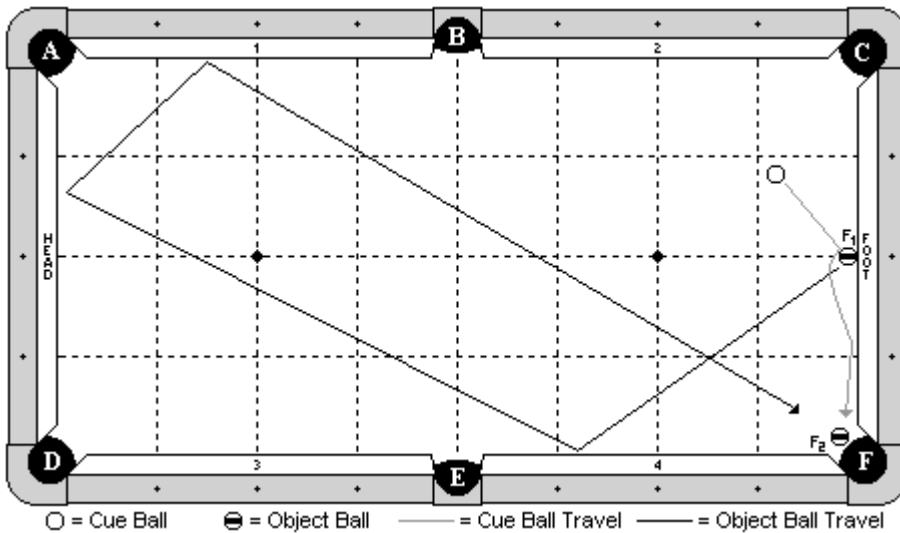

Cue Ball

In hand

Object Balls

'F1' ball is frozen to the cushion at the middle diamond. 'F2' ball is hanging near pocket 'F' and adjustable.

Objective

Shoot the cue ball into 'F1' ball, causing it to bank 4 cushions as diagrammed. The cue ball will follow down to make 'F2' ball and then get out of the way. 'F1' ball will continue to go into pocket 'F'.

Special Notes

Once the cue ball has hit 'F1' ball for the first time, 'F1' ball may not contact any other ball. It must go into pocket 'F' clean. The cue ball does not need to hit the foot cushion.

Discipline 5 – Shot 4b – 9 points

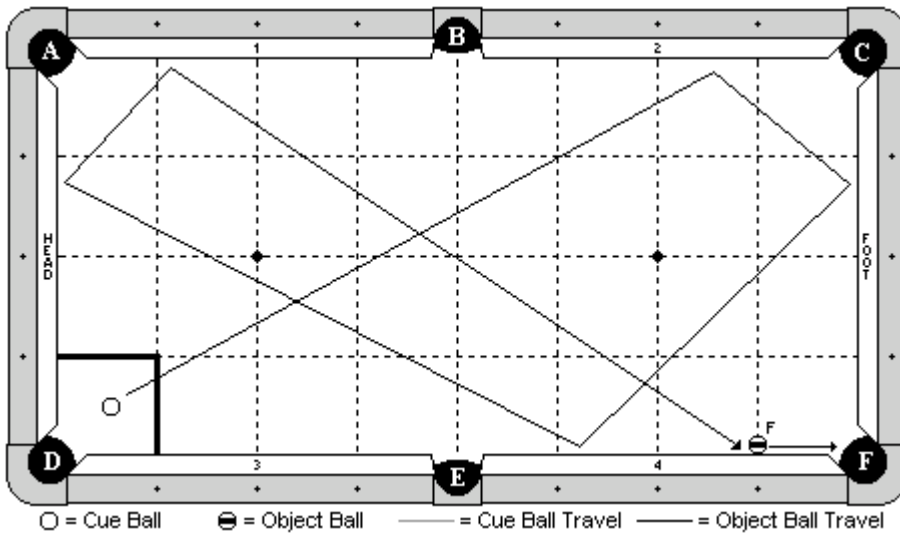

Cue Ball

In hand within the indicated zone.

Object Balls

'F' ball is in hand along the 1st diamond line.

Objective

Shoot the cue ball 5 cushions as diagrammed, and make 'F' ball in pocket 'F'.

Special Notes

None

Discipline 5 – Shot 4c – 9 points

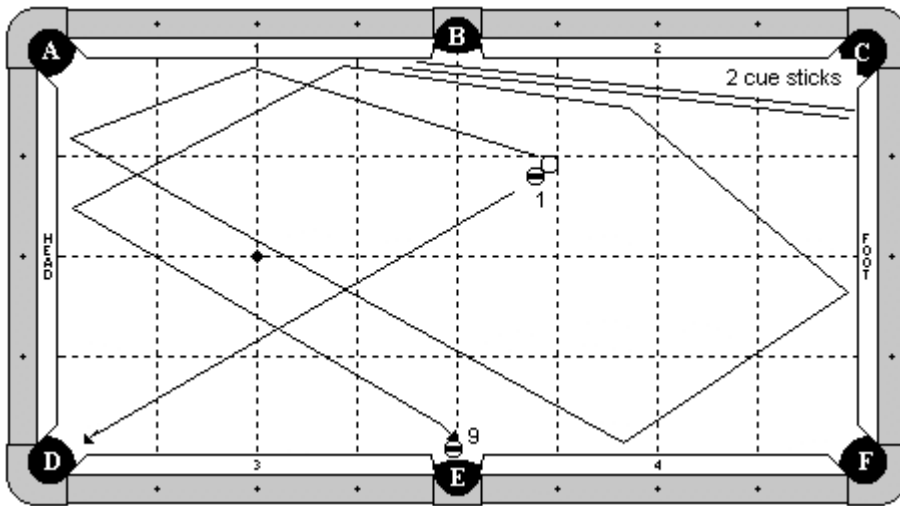

Cue Ball

In hand behind the B-E center line (on the foot cushion side of the table).

Object Balls

1 ball in hand, frozen to the cue ball, and also must be to the right of the B-E center line. 9 ball is hanging near pocket 'E'. Two cue sticks are placed on the table as diagrammed, with their butt ends near the foot cushion. Players have the option of using both cue sticks as diagrammed, or just one cue stick.

Objective

Shoot the cue ball to make the 1 ball in pocket 'D'. The cue ball will travel 4 cushions as diagrammed, hit the cue stick, then travel 2 more cushions and make the 9 ball.

Special Notes

Players selecting this shot will be required to supply the 2 cue sticks.

Discipline 5 – Shot 5a – 10 points

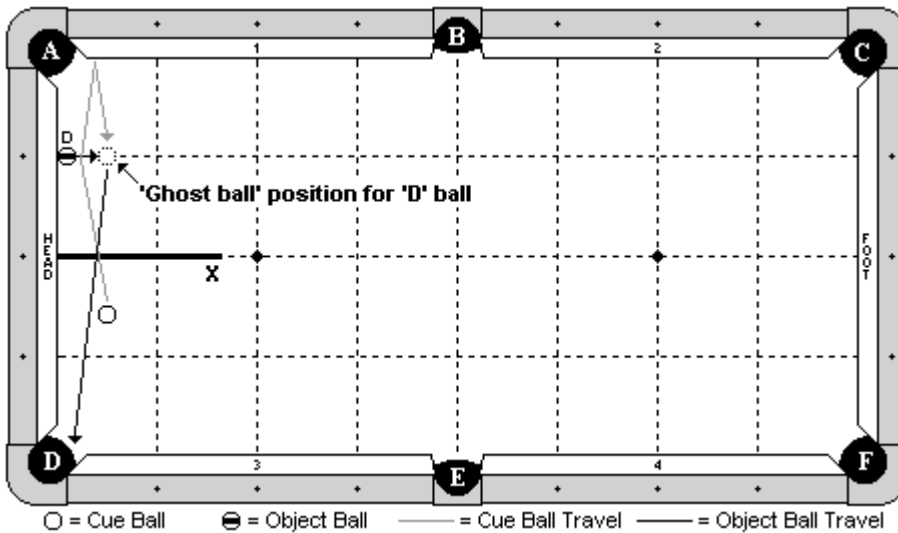

Cue Ball

In hand behind the indicated line.

Object Balls

'D' ball is frozen to the cushion on the 1st diamond.

Objective

Shoot the cue ball into 'D' ball, causing it to bounce away from the cushion slightly. The cue ball will then hit cushion 1 and kick back into 'D' ball, making it in pocket 'D'.

Special Notes

The cue ball must hit 'D' ball before hitting cushion 1.

Discipline 5 – Shot 5b – 10 points

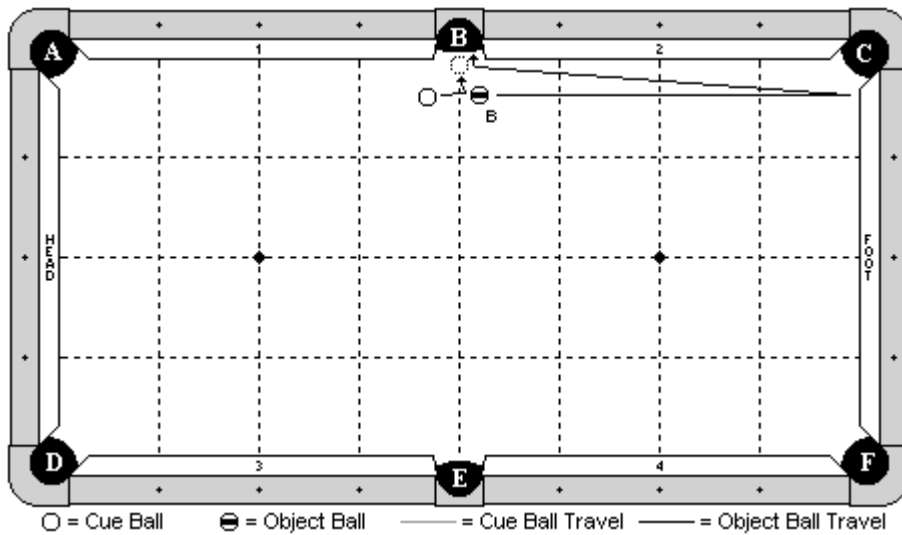

Cue Ball

In hand.

Object Balls

'B' ball in hand.

Objective

Shoot the cue ball into 'B' ball, causing it to bank off the foot cushion, optionally hit cushion 2, and then carom off the cue ball and go into pocket 'B'.

Special Notes

None

Discipline 5 – Shot 5c – 10 points

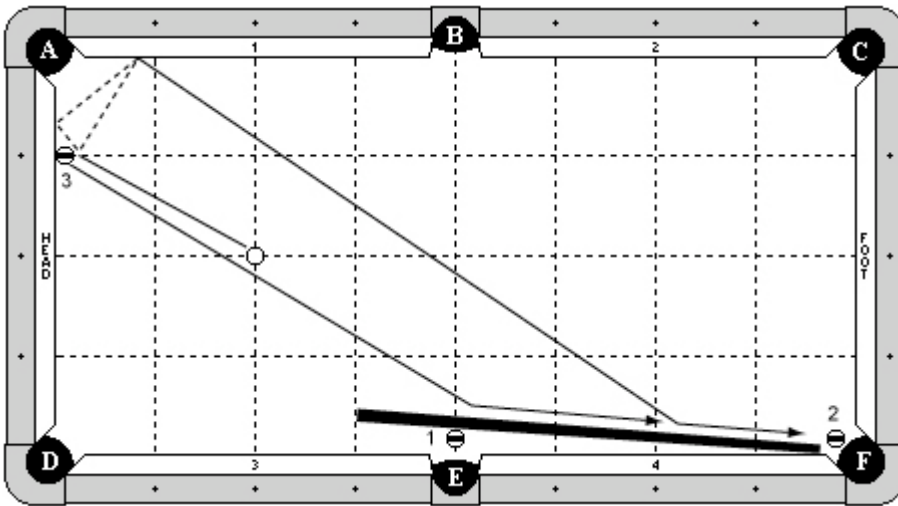

Cue Ball

On head spot.

Object Balls

3 ball frozen to head cushion, one diamond from pocket 'A'.

1 ball hanging in pocket 'E' with edge even with the pocket cut or deeper.

2 ball hanging near pocket 'F'.

A short cue is placed as diagrammed. The end of the cue may not be past one diamond to the left of pocket 'E'.

Objective

Shoot cue ball into 3 ball. 3 ball will bank into pocket 'F'. Cue ball will optionally hit the head cushion, but will hit cushion 1, then the cue stick, making 1 ball in pocket 'E', and roll down the cue stick making 2 ball in pocket 'F'. Then the 3 ball will go in to pocket 'F'.

Special Notes

All balls must be made in numerical order.

Extra contact between cue ball and 3 ball is okay.

DISCIPLINE

6

STROKE SHOTS

Discipline 6 – Shot 1a – 6 points

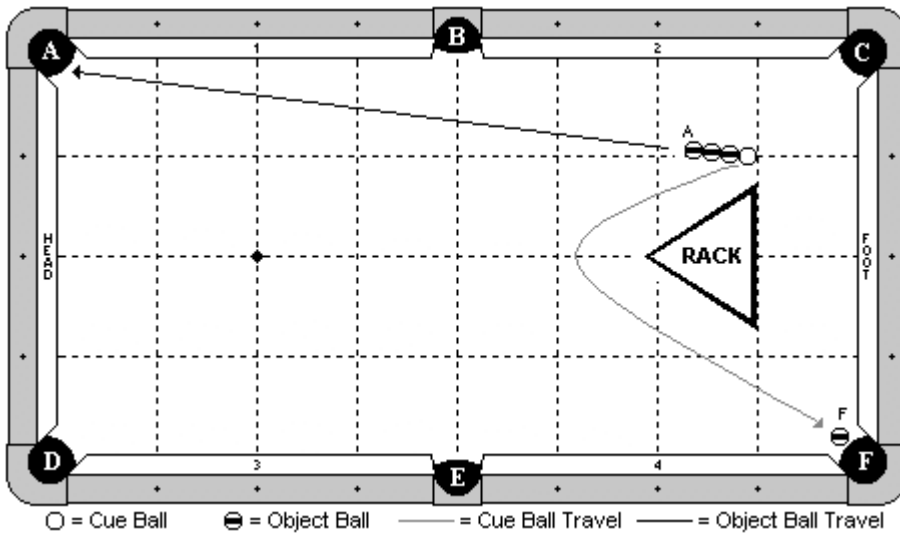

Cue Ball

In hand, but the back edge must be aligned with the 1st diamond.

Object Balls

Three balls are in line and frozen to each other and to the cue ball. 'F' ball is hanging near pocket 'F'. The rack is centered along the long center line of the table, and the back edge is aligned with the 1st diamond.

Objective

Shoot the cue ball into the line of 3 balls. The first ball ('A') will go into pocket 'A'. The cue ball will curve around the rack and make 'F' ball.

Special Notes

The other two balls in line do not need to be made. The cue ball may not contact the rack until after 'F' ball is made. Once the cue ball is struck and it separates from the line of balls, the cue ball may not be contacted by any other ball until 'F' ball is made. If the rack has a lip, it will be placed lip down.

Discipline 6 – Shot 1b – 6 points

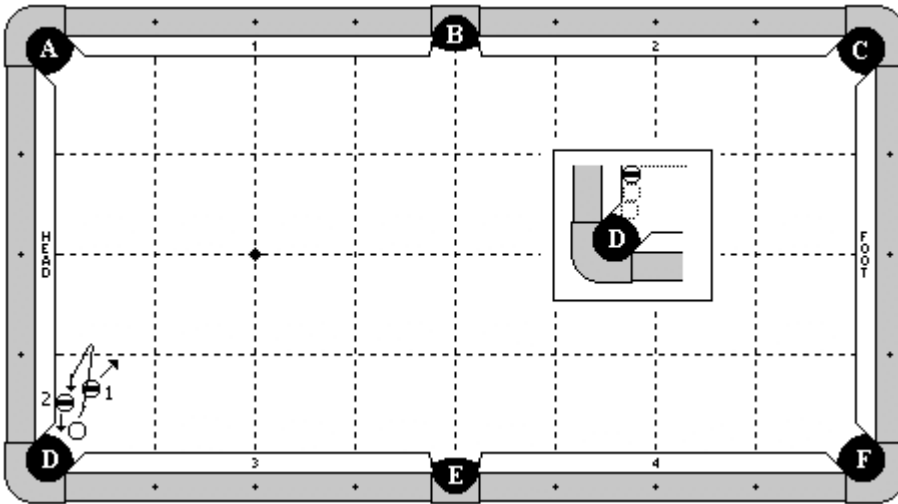

Cue Ball

In hand, but the right edge may not be past the pocket point on cushion 3.

Object Balls

2 ball is frozen to the head cushion, and is the third ball out from the pocket cut. See the close-up view for more information. The 1 ball is in hand, but may be no more than 1 chalk's width from the 2 ball. Also, the back edge of the 1 ball may not be past the forward edge of the 2 ball (indicated in the close-up view by a dotted line).

Objective

Shoot the cue ball into the 1 ball. The cue ball will jump over and draw back, making the 2 ball in pocket 'D'.

Special Notes

The cue ball may make multiple hits on the 2 ball and head cushion. The cue ball may not contact any other cushion until hitting the 2 ball on the way back. The 1 ball does not need to be made.

Discipline 6 – Shot 1c – 6 points

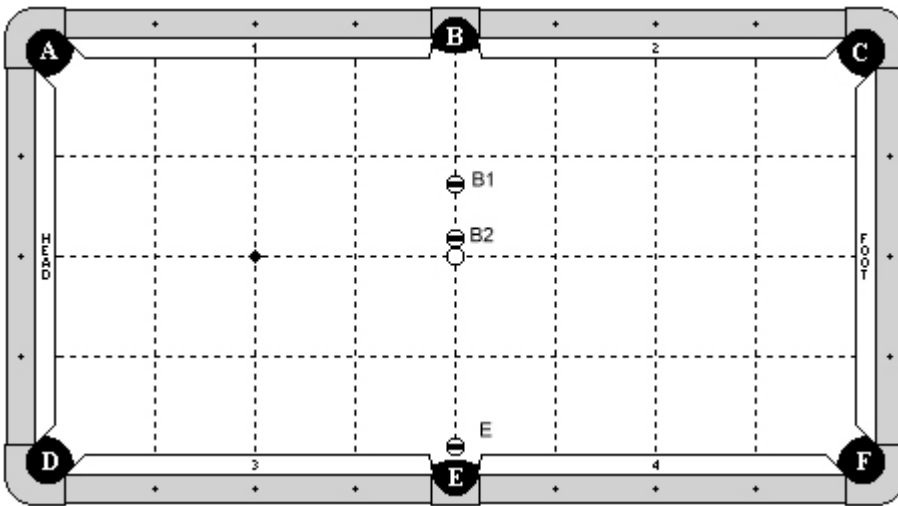

Cue Ball

On center spot.

Object Balls

All object balls on center line of table.

'B2' ball frozen to cue ball.

'B1' ball exactly two ball widths from 'B2' ball.

'E' ball hanging in pocket 'E', even with the rail line extension or deeper.

Objective

Shoot cue ball in to 'B2' ball. 'B2' ball will hit 'B1' ball in to pocket 'B'. Cue ball will contact 'B2' ball a second time, hitting it in to pocket 'B'. Cue ball will then draw back making 'E' ball.

Special Notes

'E' ball must be on center line. It is not adjustable left or right.

Discipline 6 – Shot 2a – 7 points

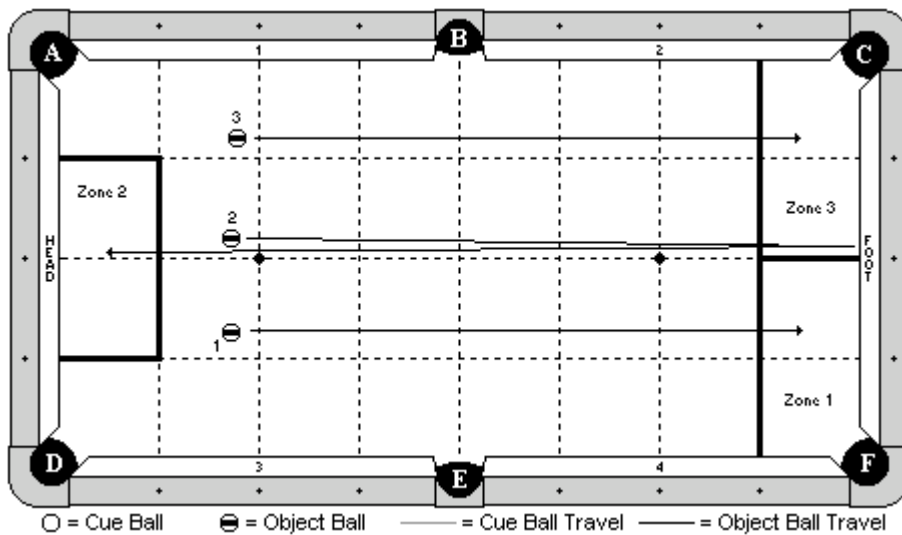

Cue Ball

None

Object Balls

All three balls are in hand behind the head string.

Objective

Shoot the 1 ball, then the 2 ball, and finally the 3 ball. The 1 ball must go straight into and stop within zone 1, the 2 ball must bank one cushion as diagrammed and stop within zone 2, and the 3 ball must go straight into and stop within zone 3.

Special Notes

The 1 ball and the 3 ball may hit the foot cushion, but no other. The 2 ball will hit the foot cushion, and may hit the head cushion, but no other. All balls must be hit before the 1 ball comes to a stop OR hits the foot cushion. Table judge decision is final.

Discipline 6 – Shot 2b – 7 points

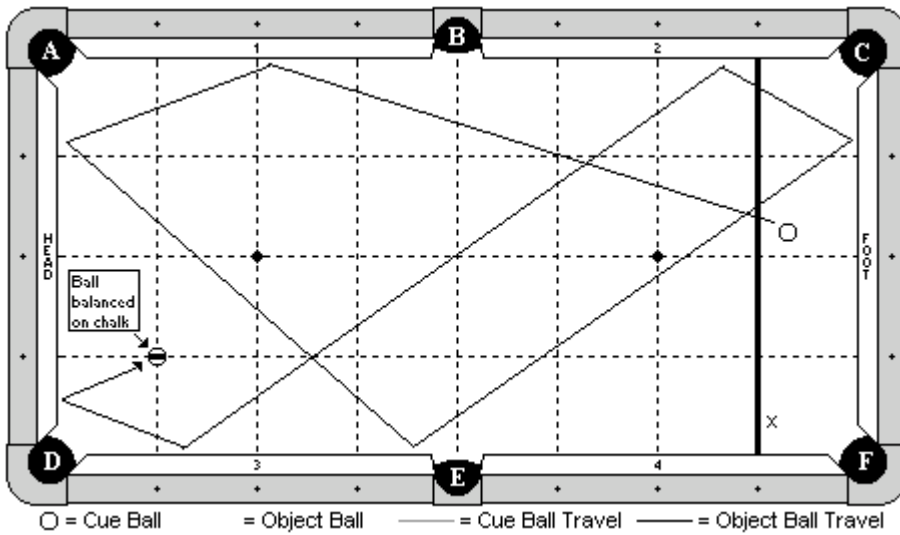

Cue Ball

In hand behind the indicated line.

Object Balls

An object ball is balanced on a piece of new chalk (well up). The chalk is centered on the 1-1 diamond intersection line, and square with the table.

Objective

Shoot the cue ball 7 cushions as diagrammed. The cue ball must make contact with the object ball and the object ball may not fall off the chalk.

Special Notes

None

Discipline 6 – Shot 2c – 7 points

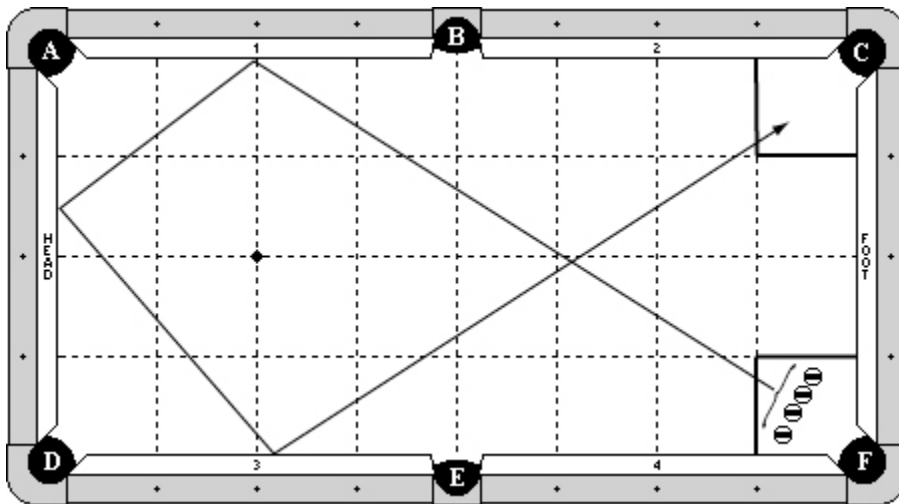

Cue Ball

None.

Object Balls

Four object balls are in hand in 1x1 diamond zone by pocket 'F'.

Objective

Shoot each object ball three rails into 1x1 diamond zone by pocket 'C'.

Special Notes

Fourth ball hit must cross in front of the first ball hit coming off the third rail.

Extra cushion contacts by pocket 'C' are allowed.

If a ball is pocketed, the shot is no good.

Extra ball contacts on the way to the finish zone are allowed.

Extra ball contacts inside the finish zone are also allowed.

All four object balls must come to rest in the 1x1 diamond zone.

Discipline 6 – Shot 3a – 8 points

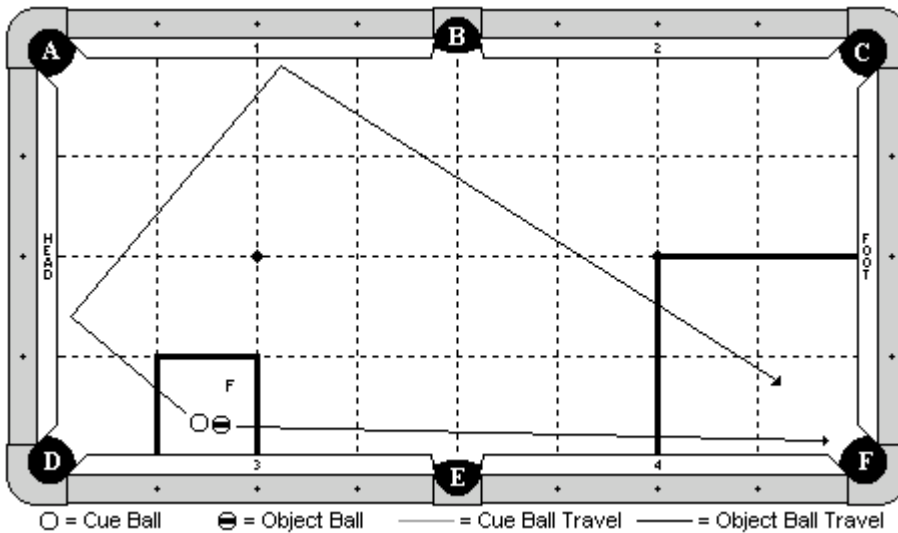

Cue Ball

In hand within the indicated zone.

Object Balls

'F' ball in hand within the indicated zone. The gap between the cue ball and 'F' ball is exactly 2mm.

Objective

Shoot the cue ball and make 'F' ball in pocket 'F'. The cue ball will draw 2 cushions as diagrammed, and come to rest within the indicated zone.

Special Notes

If the cue ball scratches in pocket 'F', the shot is good.

Discipline 6 – Shot 3b – 8 points

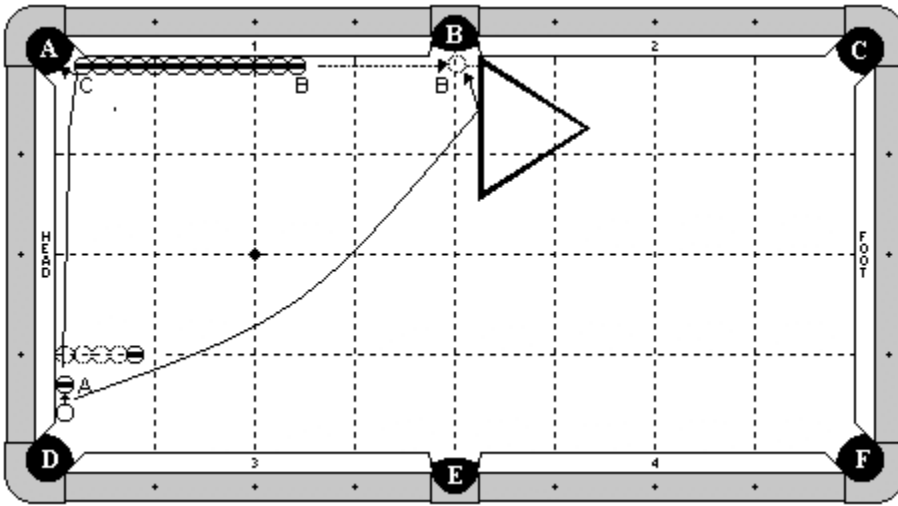

Cue Ball

Frozen to the head cushion, and the back edge is aligned with the pocket point.

Object Balls

'A' ball frozen to the head cushion and adjustable. 13 balls are in line, all frozen to cushion 1. The first ball ('C') may be inside the pocket jaws. A blocker ball is on the 1st diamond, exactly 4 ball's width from the cushion. A rack is wedged into the side pocket, and the left edge is perpendicular to the cushion.

Objective

Shoot the cue ball into the 'A' ball, making it in pocket 'A'. The ball will carom off 'C' ball, causing 'B' ball to travel up the rail, hit the rack, and sit in front of the pocket. The cue ball will curve around the blocker ball and make 'B' ball in pocket 'B', optionally hitting the rack on its way.

Special Notes

The blocker ball may not be contacted by any means until after 'B' ball has been made. The rack must be perpendicular. When 'B' ball hits the rack, it may not go in on its own. It must sit there and wait for the cue ball to knock it in.

Discipline 6 – Shot 3c – 8 points

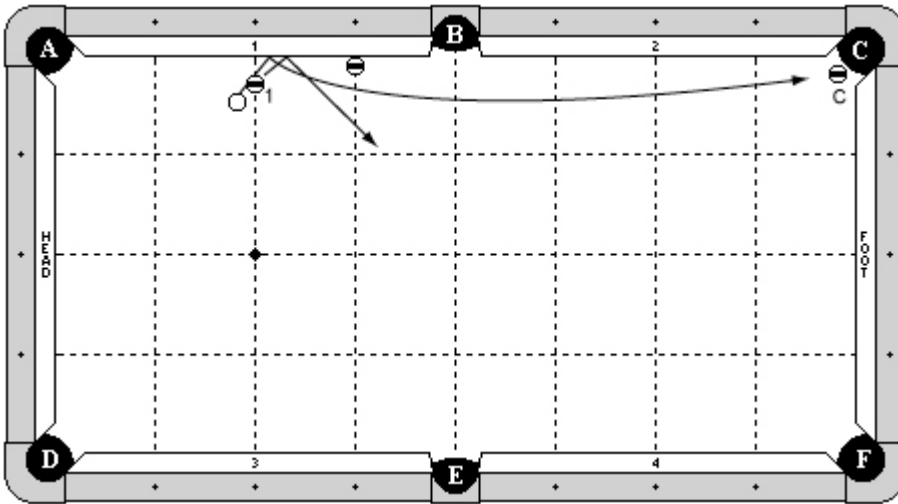

Cue Ball

In hand, less than one chalk width from 1 ball.

Object Balls

1 ball is 1 ball width from cushion one on second diamond line.

Blocker ball is frozen to cushion 1 at third diamond.

'C' ball is hanging in pocket 'C'.

Objective

Shoot cue ball in to 1 ball. 1 ball will hit cushion 1 and bank out of the way. Cue ball will follow into cushion one, rebound out and around the blocker ball and continue up table to make 'C' ball in pocket 'C'.

Special Notes

Cue ball and 1 ball may not re-contact each other after initial hit.

Cue ball must make 'C' ball.

Discipline 6 – Shot 4a – 9 points

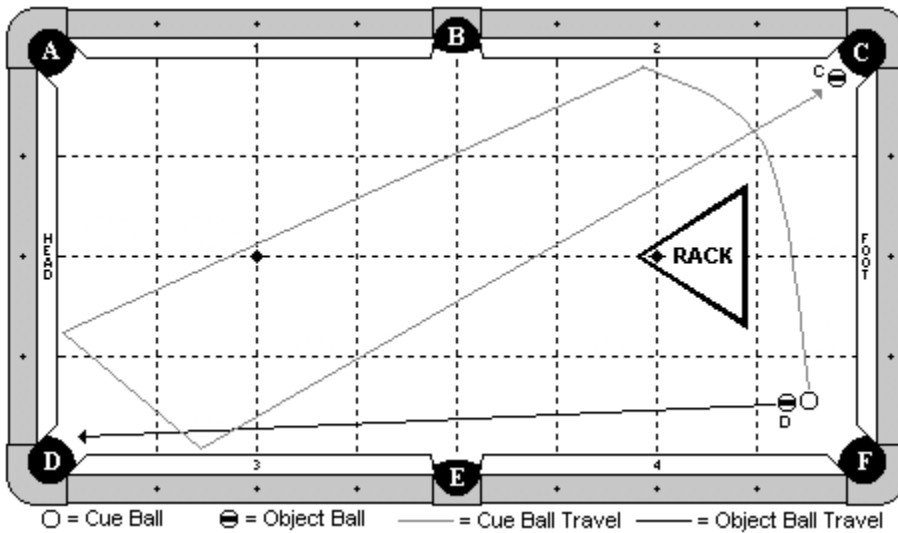

Cue Ball

The cue ball must be at least 2 ball's width off the foot cushion. It may not be more than 3 ball's width off cushion 4.

Object Balls

'C' ball hanging near pocket 'C'. 'D' ball is near the cue ball and adjustable. The rack is placed in its normal position for racking. If the rack has a lip, it will be placed lip down.

Objective

Shoot the cue ball making 'D' ball in pocket 'D'. The cue ball will curve around the rack as diagrammed, travel 3 cushions, and make 'C' ball.

Special Notes

The rack may not be touched by any means until after 'C' ball is made.

Discipline 6 – Shot 4b – 9 points

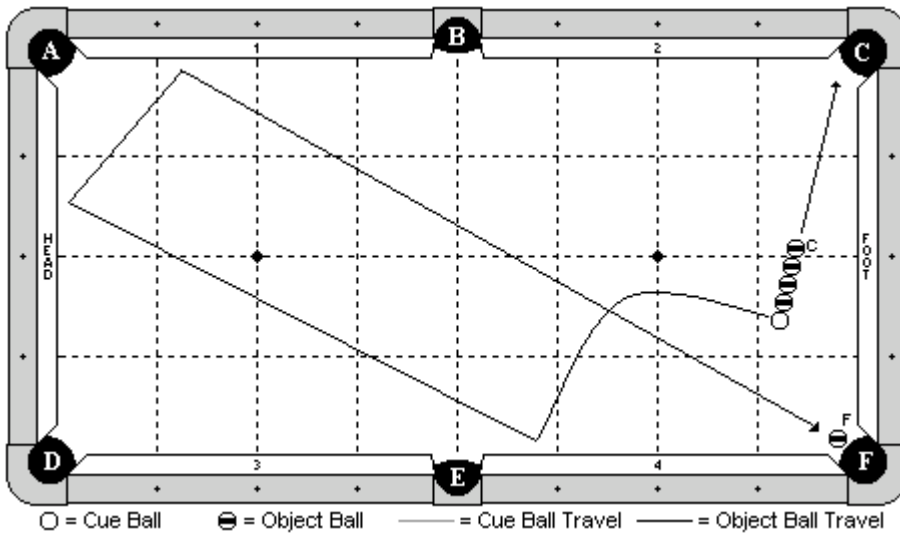

Cue Ball

In hand, but no more than 2 diamonds away from the foot cushion.

Object Balls

4 balls are frozen in line, and to the cue ball. 'F' ball is hanging near pocket 'F'.

Objective

Shoot the cue ball into the line of 4 balls. The first ball in line ('C') will go into pocket 'C'. The cue ball will draw back and around 3 cushions as diagrammed, and make 'F' ball.

Special Notes

The other 3 balls in the line do not need to be made. The cue ball may hit cushion 3 or 4 as the first cushion.

Discipline 6 – Shot 4c – 9 points

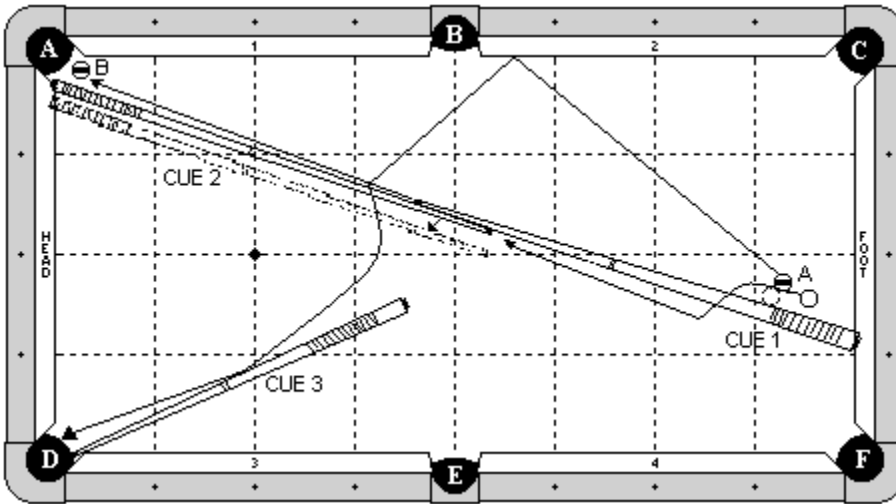

Cue Ball

In hand, but may not be more than 1 chalk's width from 'A' ball.

Object Balls

'A' ball is approximately 1 ball's width from the cue stick, but it is adjustable. 'B' ball is hanging near pocket 'A'. Three cue sticks are on the table. Cue stick # 1 has the butt end against the foot cushion at the 1st diamond. Cue stick # 2 has the butt end against the head cushion. Both cue stick # 1 and # 2 meet at the tip end and the sticks are both lined up so there is no gap between the sticks where they meet. Cue stick # 3 has the tip end wedged into pocket 'D' and it adjustable.

Objective

Shoot the cue ball into 'A' ball. 'A' ball will bank off cushion 2, hit and jump over the sticks (separating them), hit cue stick # 3 (optional), and go into pocket 'D'. The cue ball will jump over cue stick # 1, follow between the gap that now exists between the two cue sticks, and make 'B' ball in pocket 'A'.

Special Notes

The cue ball may hit cue stick # 1 when jumping over it. The cue ball must make 'B' ball. It may not be hit in by the cue stick. Players selecting this shot are required to supply the 3 cue sticks.

Discipline 6 – Shot 5a – 10 points

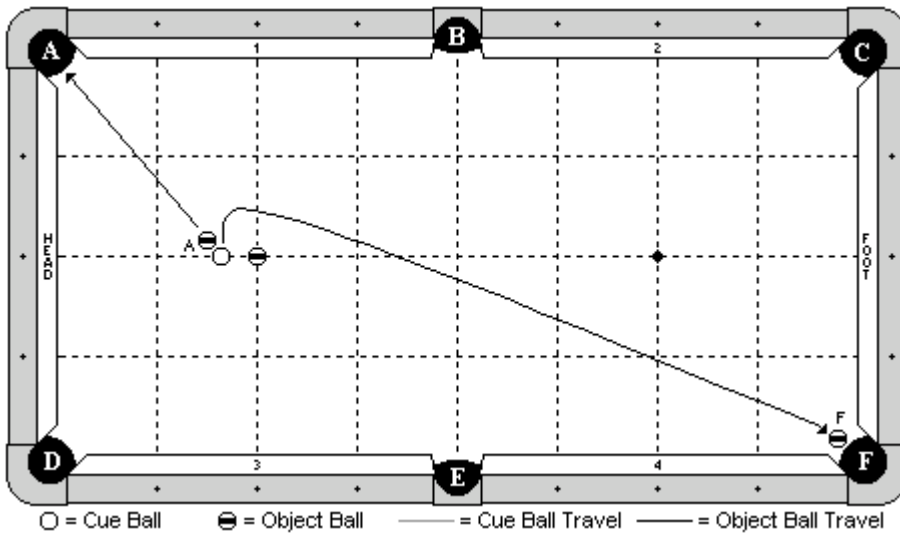

Cue Ball

On the long center line of the table, exactly 1 ball's width from the ball on the head spot.

Object Balls

A blocker ball is on the head spot. Ball 'A' is exactly 2mm from the cue ball. 'F' ball is hanging near pocket 'F'.

Objective

Shoot the cue ball making 'A' ball in pocket 'A'. The cue ball will draw around the blocker ball, and make 'F' ball.

Special Notes

The blocker ball may not be touched by any means until after 'F' ball is made. Players may not jack up and execute a full masse to make this shot.

Discipline 6 – Shot 5b – 10 points

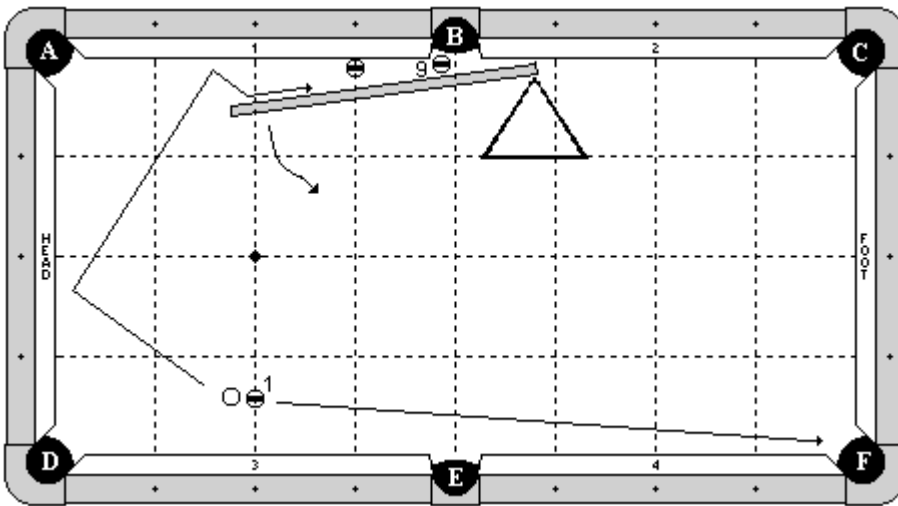

Cue Ball

In hand, but must be exactly 2mm from the 1 ball.

Object Balls

1 ball on the 2nd diamond, and no more than 3 ball's width from the cushion. 9 ball is hanging near pocket 'B'. A blocker ball is frozen to cushion 1 and on the 3rd diamond. A short jump cue is in position as diagrammed. It is adjustable, but it may be no more than 1 chalk's width from the blocker ball. A rack is in position to keep the jump cue from moving too much.

Objective

Shoot the cue ball into the 1 ball, making it in pocket 'F'. The cue ball will draw back into the head cushion, and then go into the gap between the cue stick and the cushion. The cue ball will swing the jump cue out so the cue ball can go around the blocking ball, and make the 9 ball.

Special Notes

It is okay for the cue ball to hit the blocker ball, provided that the cue ball (not the blocker or the stick) makes the 9 ball. Players selecting this shot will be required to provide the jump cue.

Discipline 6 – Shot 5c – 10 points

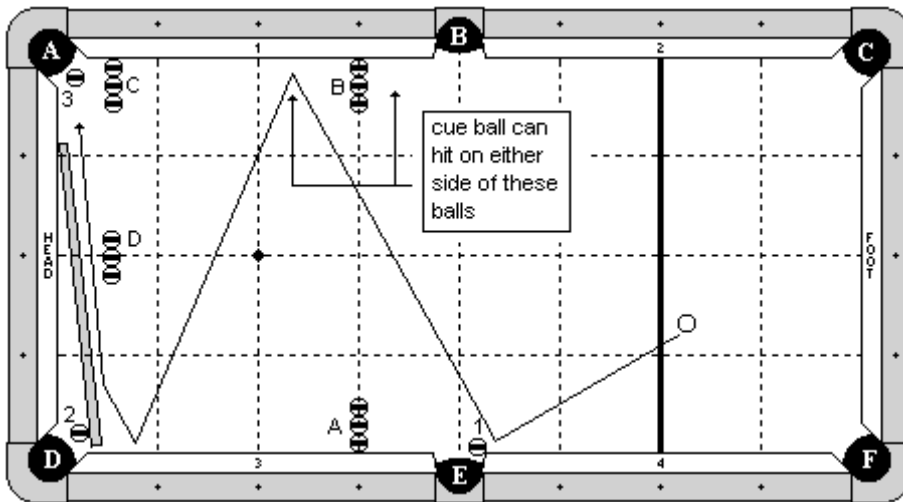

Cue Ball

In hand behind foot string.

Object Balls

1, 2, and 3 balls hanging in their respective pockets.

Four sets of three blocker balls are positioned as diagrammed. Set A is frozen to cushion 3 one diamond from pocket 'E'. Set B is frozen to cushion 1 one diamond from pocket 'B'. Set C is frozen to cushion 1 at one-half diamond from pocket 'A'. Set D is one-half diamond from head cushion centered along the long center line of the table.

A cue butt is positioned as diagrammed, frozen to ball 2.

Objective

Shoot cue ball into 1 ball, pocketing it in pocket 'E'. Cue ball will hit cushion 1 then cushion 3. Cue ball will then hit the cue butt, pocketing 2 ball in pocket 'D', roll down the cue butt and pocket 3 ball in pocket 'A'.

Special Notes

Cue ball must hit cushion 3 before cue butt.

Blocker balls may not be disturbed by any means until all 3 balls are pocketed.

DISCIPLINE

7

JUMP SHOTS

Discipline 7 – Shot 1a – 6 points

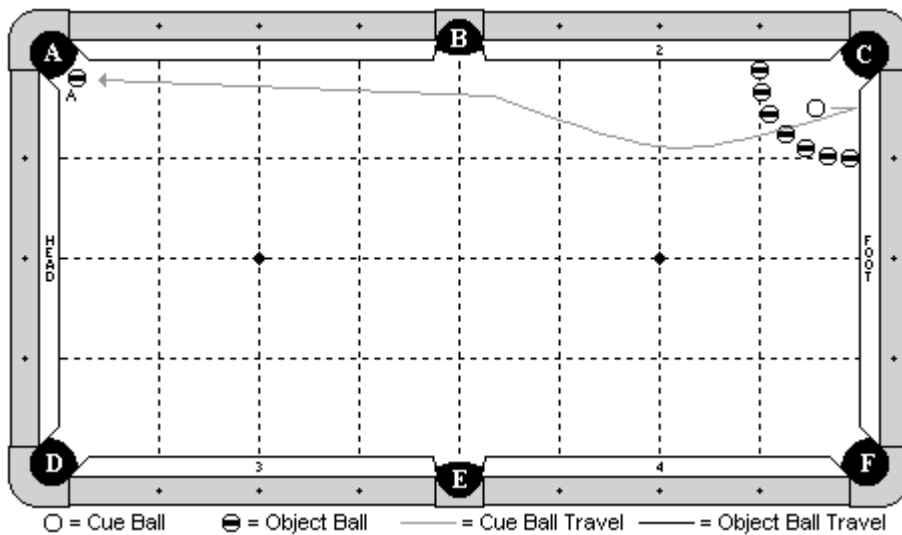

Cue Ball

In hand within the ring of balls.

Object Balls

7 balls form an arc, with the first ball on each end frozen to the cushion at the 1st diamond. The other balls are evenly spaced. 'A' ball is hanging near pocket 'A'.

Objective

Shoot the cue ball into the foot cushion, causing it to jump back and over the ring of balls, and make 'A' ball in pocket 'A'.

Special Notes

The blocker balls may not be contacted by any means until after 'A' ball is made.

Discipline 7 – Shot 1b – 6 points

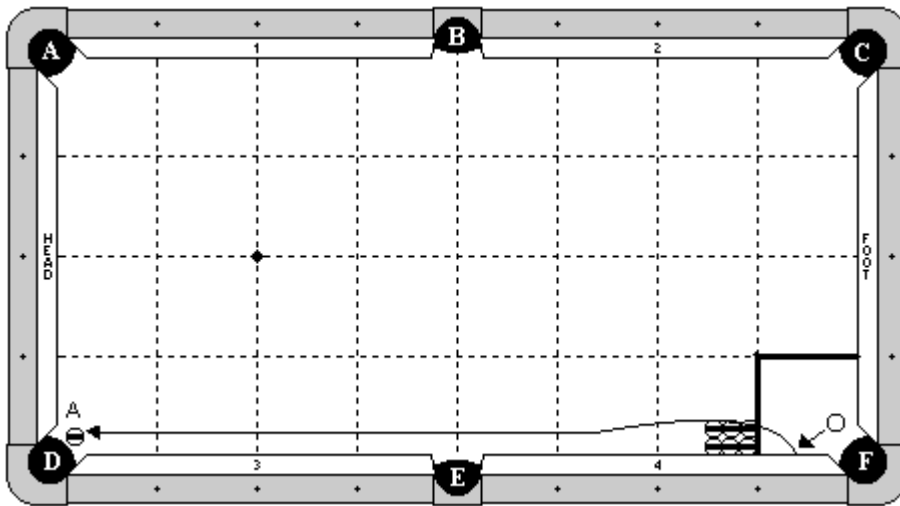

Cue Ball

In hand within the 1x1 diamond zone at least one chalk width from cushion 4.

Object Balls

'A' ball is hanging near pocket 'D'. 6 blocker balls form a 2x3 cluster. All balls are frozen to each other. The three balls along the rail are frozen to the rail. The right most 2 balls have their edge aligned with the 1st diamond.

Objective

Shoot the cue ball into cushion 4, causing it to jump over the blocker balls, and travel down to make the 'A' ball in pocket 'D'.

Special Notes

The blocker balls may not be contacted by any means until after 'A' ball is made.

Discipline 7 – Shot 1c – 6 points

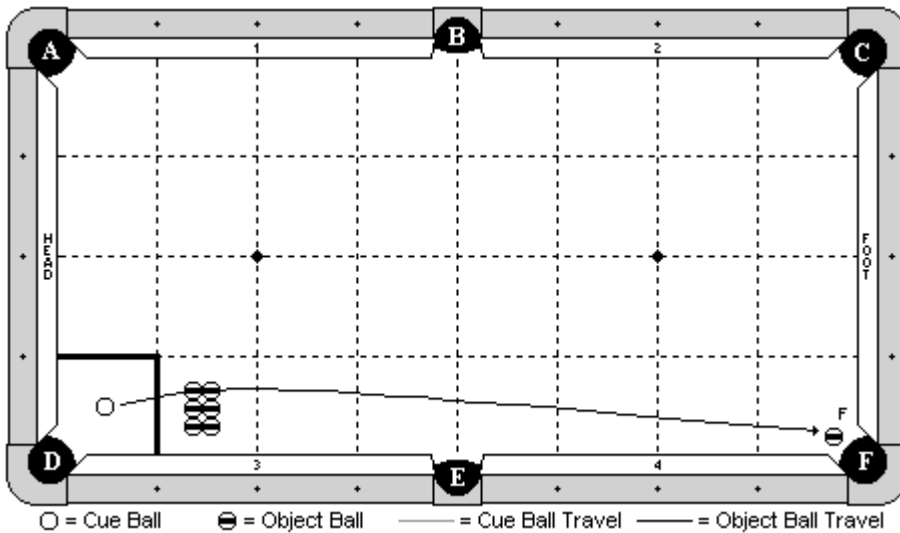

Cue Ball

In hand within the 1x1 diamond zone indicated. It must be positioned so that it will jump over the center of the cluster of blocking balls (approximately).

Object Balls

'F' ball is hanging near pocket 'F'. A 2x3 cluster of balls are all frozen to each other and are in hand within the 1x1 diamond zone immediately to the right of the cue ball's 1x1 diamond zone.

Objective

Jump the cue ball 1-handed, jacked up, over the blocker balls, and make 'F' ball.

Special Notes

The blocker balls may not be contacted by any means until after 'F' ball is made.

Discipline 7 – Shot 2a – 7 points

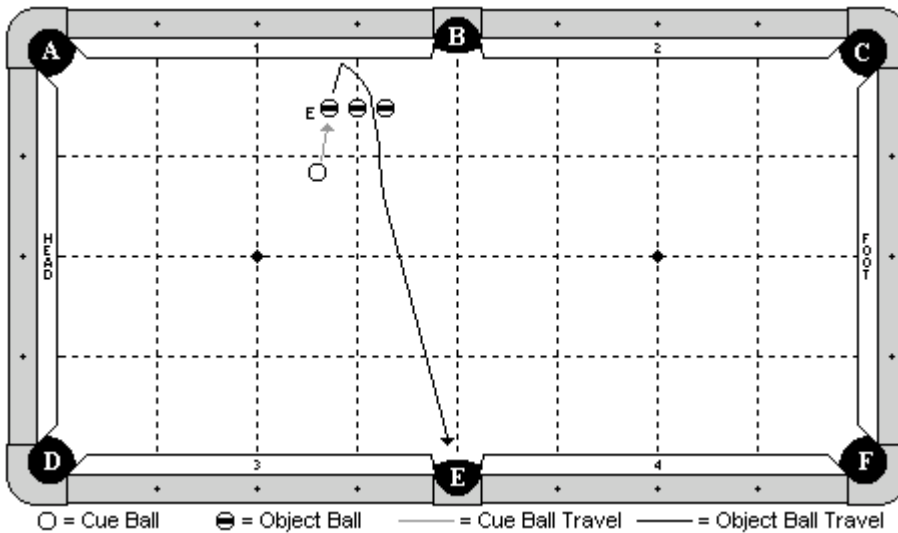

Cue Ball

In hand.

Object Balls

Three object balls are in position as diagrammed. All balls are exactly 2 ball's width off the cushion, and the center ball is on the 3rd diamond line. The other balls have a gap of 1 chalk's width between the balls.

Objective

Shoot the cue ball into 'E' ball, causing it to hit the cushion and jump over the other balls into pocket 'E'.

Special Notes

The two blocking balls may not be contacted by 'E' ball, but the cue ball may hit them. Decision by the table judge is final.

Discipline 7 – Shot 2b – 7 points

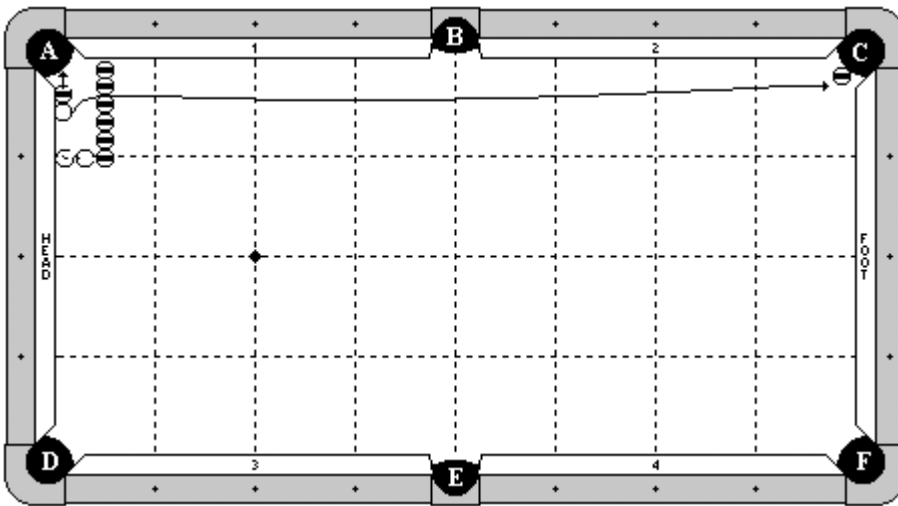

Cue Ball

In hand between head cushion and blocker balls.

Object Balls

'A' ball is in hand, but frozen to the cue ball.

'C' ball is hanging in pocket 'C'.

A row of 6 blocker balls is exactly two ball widths from head cushion.

Objective

Jump cue ball over the blocker balls. 'A' ball will go in to pocket 'A'. Cue ball will hit 'C' ball in to pocket 'C'.

Special Notes

Blocker balls may not be contacted by any means until after object balls are made.

Discipline 7 – Shot 2c – 7 points

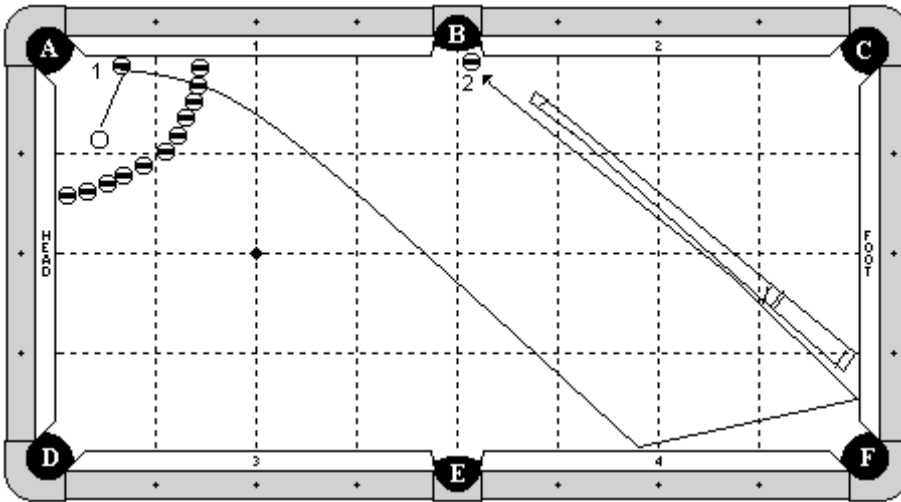

Cue Ball

In hand within circle of balls, at least one ball width away from 1 ball.

Object Balls

1 ball is frozen to cushion 1, within the circle of balls.

2 ball is hanging in pocket 'B'.

A circle of blocking balls are placed as diagrammed, with the first and last balls at 1 ½ diamond segments.

A cue stick is placed so the butt end is frozen to the foot cushion at the 1st diamond from pocket 'F'.

Objective

Shoot the cue ball into the 1 ball. The cue ball will jump over the blocking balls contacting cushion 4, foot cushion, the cue stick, and pocketing 2 ball in pocket 'B'.

Special Notes

The cue ball does not have to contact the cue stick.

The cue ball may not contact the blocking balls.

The 1 ball may contact the blocking balls.

Discipline 7 – Shot 3a – 8 points

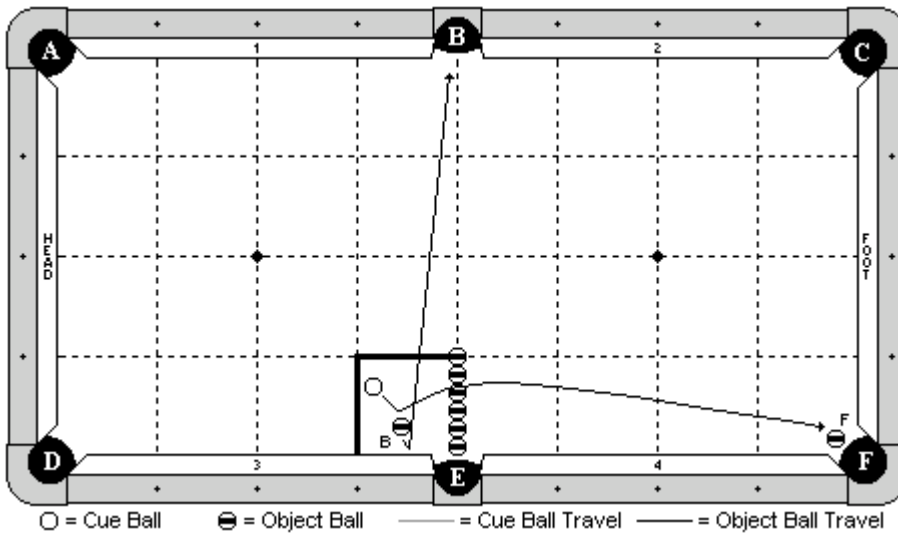

Cue Ball

In hand, but must be at least one ball width from 'B' ball.

Object Balls

'B' ball is in hand within the indicated zone. 'F' ball is hanging near pocket 'F'. 6 blocker balls are on the center line and frozen to each other, with the last ball in line exactly 1 diamond from pocket 'E'.

Objective

Shoot the cue ball into 'B' ball, causing it to bank into pocket 'B'. The cue ball will jump over the blocker balls, and make 'F' ball.

Special Notes

The blocker balls may not be touched by any means until after 'F' ball is made.

Discipline 7 – Shot 3b – 8 points

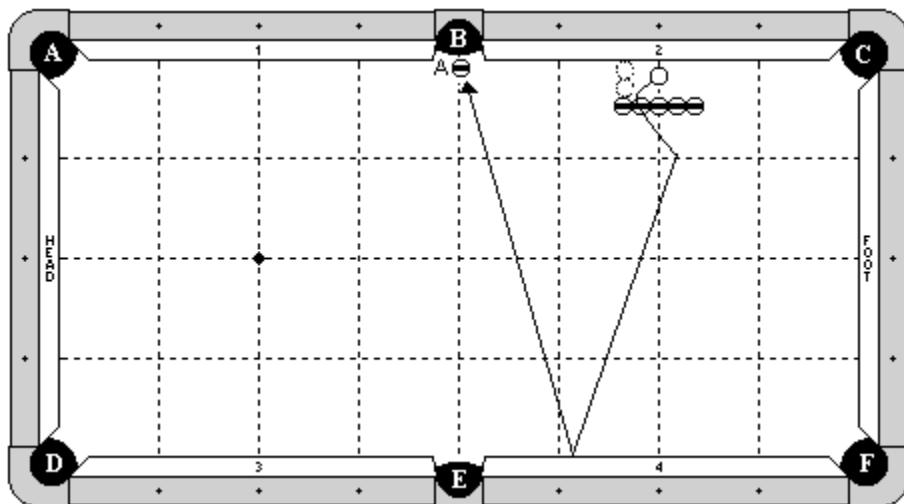

Cue Ball

In hand between the blocker balls and the cushion. The cue ball may not be adjusted left or right so that the edge passes the 2nd diamond line.

Object Balls

A row of 5 object balls are exactly 2 ball's width off the cushion. The center ball is on the 2nd diamond line. 'A' ball is hanging near pocket 'B'.

Objective

Jump the cue ball over the blocker balls, bank one rail, and make 'A' ball.

Special Notes

The blocker balls may not be touched by any means until after 'A' ball is made.

Discipline 7 – Shot 3c – 8 points

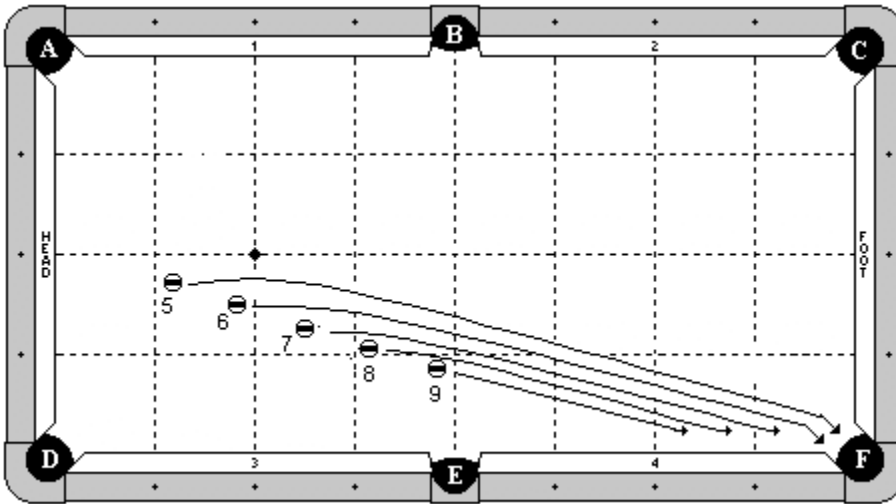

Cue Ball

None

Object Balls

The 5 through 9 balls are lined straight towards pocket 'F'. They are in hand to the left of the B-E center line, but they must be all straight in line with each other and towards pocket 'F'.

Objective

Jump the 5 ball, then the 6 ball, then the 7 ball, and finally the 8 ball. Each will be jumped into pocket 'F'. Lastly, shoot the 9 ball straight into pocket 'F'.

Special Notes

When jumping a ball, none of the other balls may be disturbed by any means.

Discipline 7 – Shot 4a – 9 points

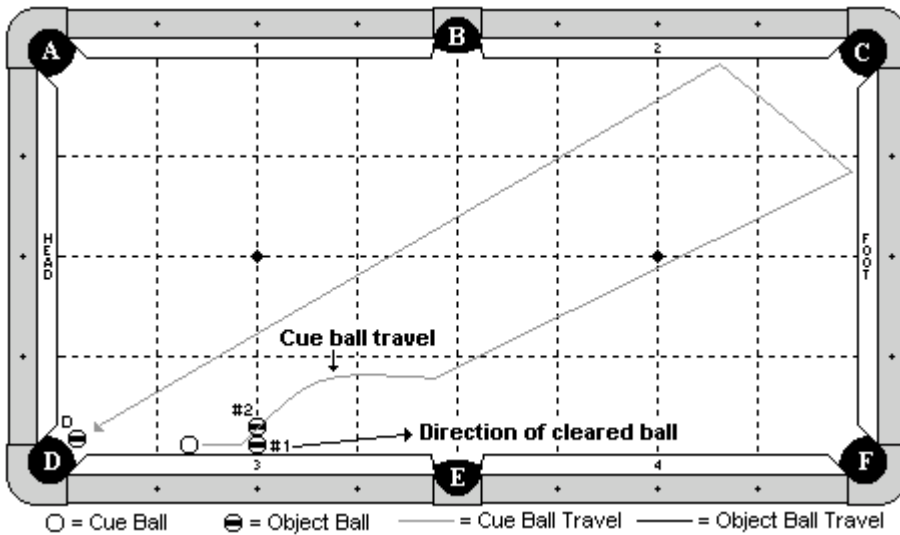

Cue Ball

In hand, frozen to cushion 3.

Object Balls

1 ball and 2 ball are frozen in line on the 2nd diamond, with the 1 ball frozen to the cushion. 'D' ball is hanging.

Objective

Shoot the cue ball into the 1 ball. The cue ball will jump over the 2 ball, travel 2 cushions as diagrammed, and make 'D' ball.

Special Notes

The 2 ball may not move by any means until after 'D' ball is made.

Discipline 7 – Shot 4b – 9 points

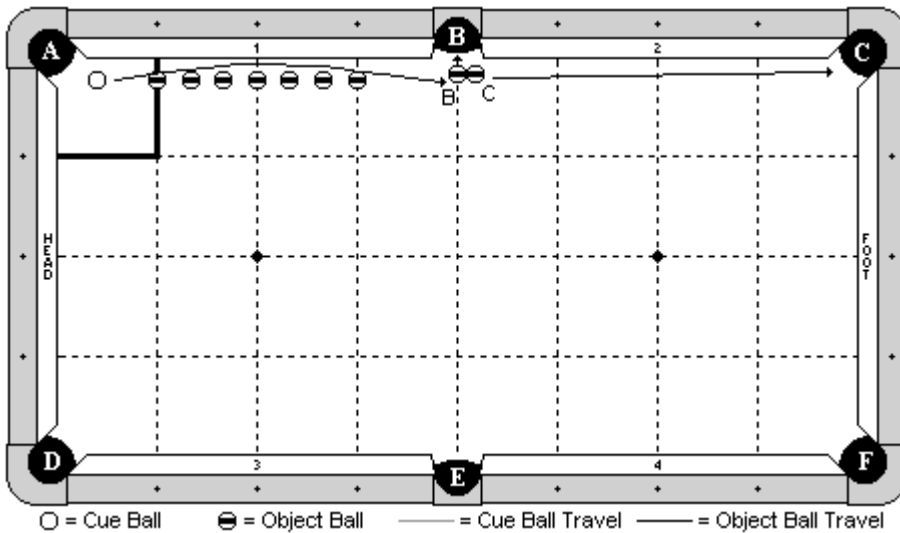

Cue Ball

In hand within the indicated zone, but must be directly in line with the other balls.

Object Balls

'B' and 'C' balls are as diagrammed near pocket 'B'. They must be directly in line with the other balls. 7 blocker balls are in a straight line. The end balls are on the 1st and 3rd diamond lines, and the middle ball is on the 2nd diamond line. The blockers may not be more than 1 chalk's width off the cushion. All balls, including the cue ball and the balls near pocket 'B' must be in a straight line.

Objective

Jump the cue ball over the line of blockers, and make 'B' ball in pocket 'B' and 'C' ball in pocket 'C'.

Special Notes

The blocker balls may not be contacted by any means until after the cue ball has contacted 'B' ball.

Discipline 7 – Shot 4c – 9 points

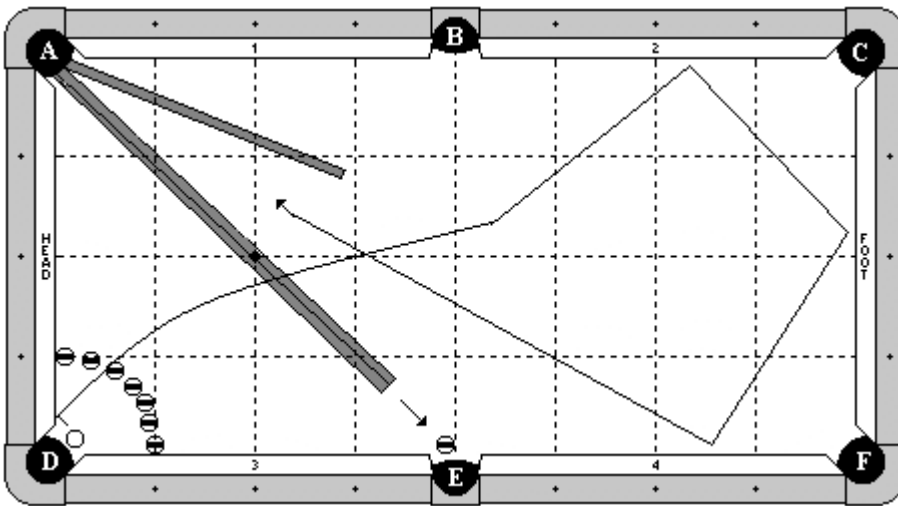

Cue Ball

In hand within the jaws of pocket 'D'. It does not need to be frozen to the jaw, but the base may not be further out than the line between the pocket points.

Object Balls

7 blocker balls form a ring as diagrammed, with the first balls on either side frozen to the cushion at the 1st diamond. The other balls are spaced evenly. A ball is hanging near pocket 'E'. Two regular cue sticks and one short stick form the classic 'railroad' formation as diagrammed.

Objective

Shoot the cue ball into the pocket point or the head cushion. The cue ball will jump over the ring of balls and over the sticks, travel 3 cushions as diagrammed, enter the 'railroad', go up the sticks, turn the corner, and come down the two regular sticks, to make the ball in pocket 'E'.

Special Notes

The blocker balls may not be contacted by any means until after 'E' ball is made. The cue ball may contact the sticks when jumping over them, but the player may not readjust the sticks during the course of the shot. The player selecting this shot is required to supply the cue sticks.

Discipline 7 – Shot 5a – 10 points

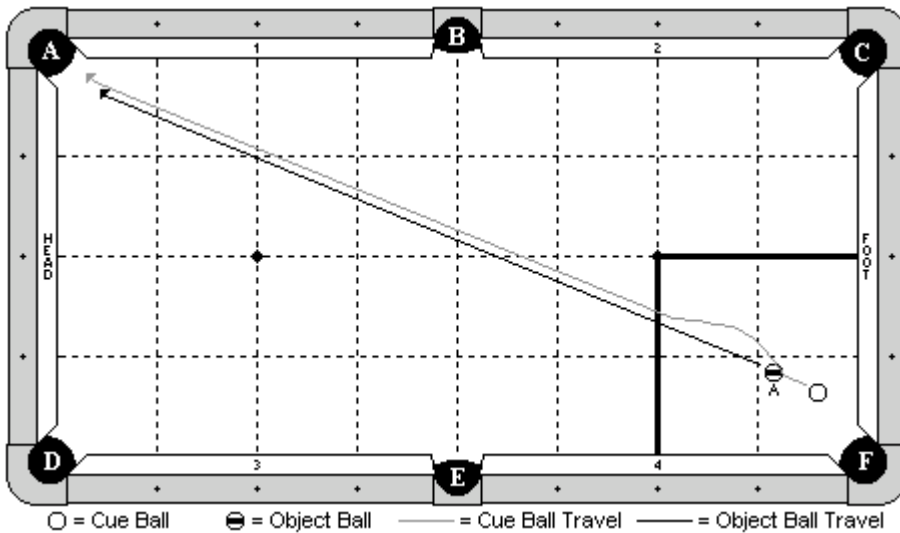

Cue Ball

In hand within the indicated zone.

Object Balls

'A' ball is in hand within the indicated zone.

Objective

Jump the cue ball into 'A' ball. The cue ball will skim the top of 'A' ball, causing it to roll towards pocket 'A'. The cue ball will jump over the ball and go into pocket 'A' first, followed by 'A' ball.

Special Notes

None

Discipline 7 – Shot 5b – 10 points

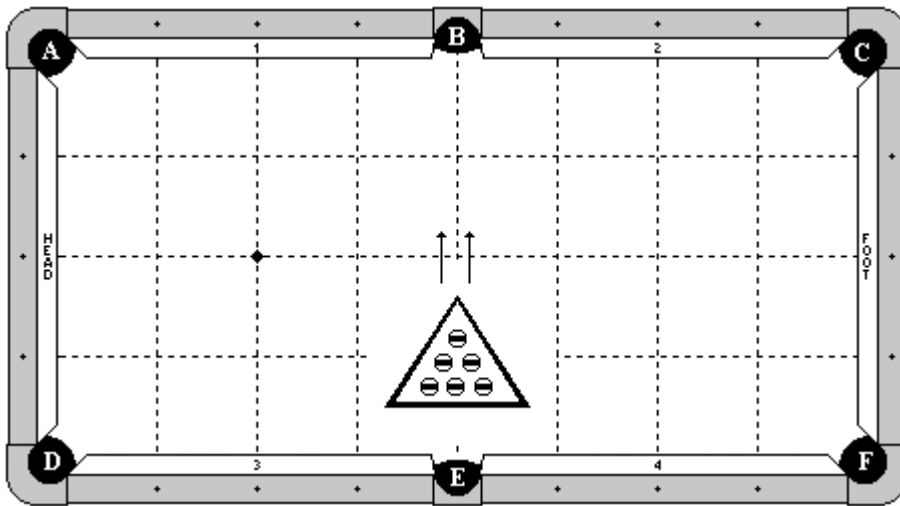

Cue Ball

None

Object Balls

6 object balls are in hand within a rack. A rack is placed centered on the B-E center line. The point of the rack may not pass the long center line of the table.

Objective

Using a 1-handed jacked up stroke, jump all object balls out of the rack, one at a time, into pocket 'B'.

Special Notes

The rack may not be contacted by any means. When jumping a ball, no other ball may be disturbed.

Discipline 7 – Shot 5c – 10 points

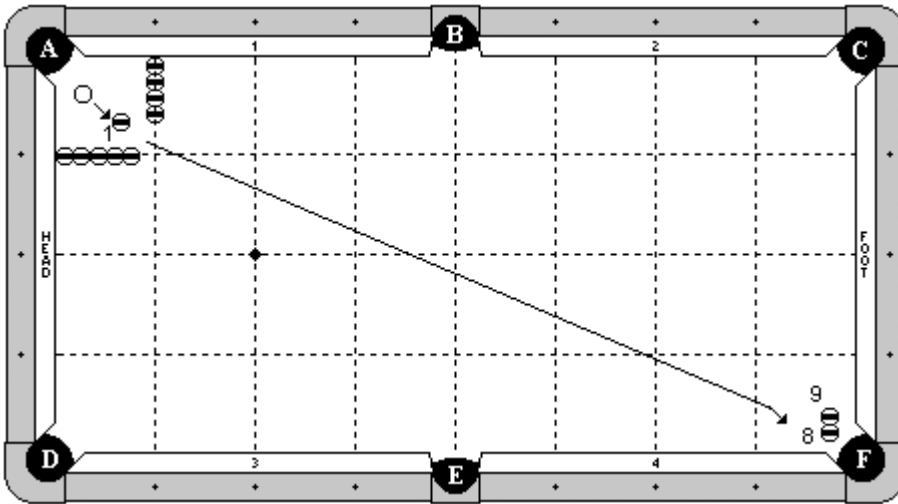

Cue Ball

In hand within the 1x1 diamond zone.

Object Balls

1 ball in hand within the 1x1 diamond zone. 8 ball is a special stacking ball near pocket 'F'. 9 ball is balanced on top of it. 4 balls are frozen in line on the 1st diamond, with the first ball frozen to cushion 1. 5 balls are frozen in line on the 1st diamond, with the first ball frozen to the head cushion.

Objective

Shoot the cue ball into the 1 ball, causing it to roll towards the stacked balls. Re-hit the cue ball, jumping it over the 1 ball. The cue ball will make the 8 ball (bottom ball), and get of the way. The 1 ball will then make the 9 ball, which fell in place.

Special Notes

The cue ball, 1 ball, and stacked balls must all be in line. The blocker balls may not be contacted by any means until after the 8 ball is made. The 9 ball must be made by the 1 ball. It may not fall on its own or be made by the cue ball. After the initial contact between the cue ball and 1 ball, the 1 ball may not contact any other ball until it hits the 9 ball.

DISCIPLINE

8

MASSE SHOTS

Discipline 8 – Shot 1a – 6 points

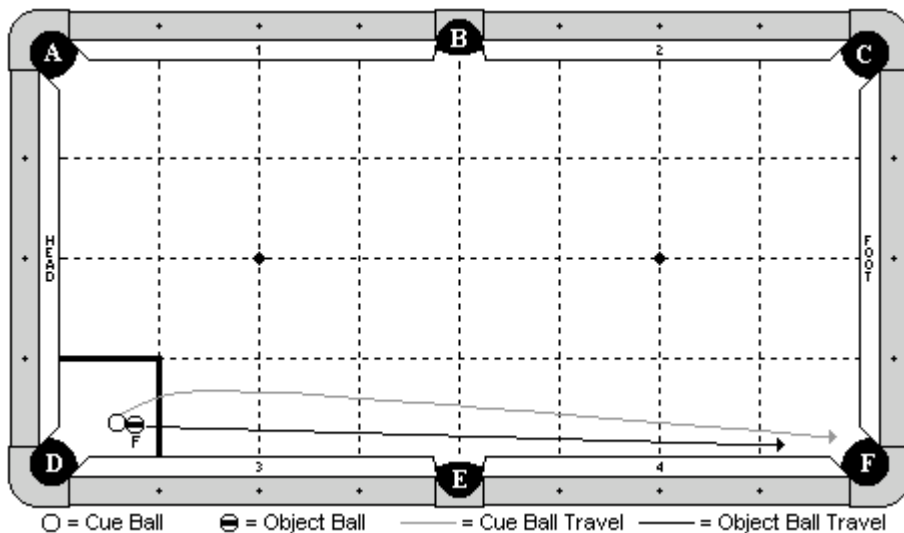

Cue Ball

In hand within the indicated zone.

Object Balls

'F' ball in hand within the indicated zone, frozen to the cue ball.

Objective

Shoot the cue ball, making 'F' ball in pocket 'F'. The cue ball will move out to the left, speed up and pass 'F' ball, and go into pocket 'F' first.

Special Notes

Multiple contact between the two balls are allowed, provided that the cue ball goes into pocket 'F' first. Decision by the table judge is final.

Discipline 8 – Shot 1b – 6 points

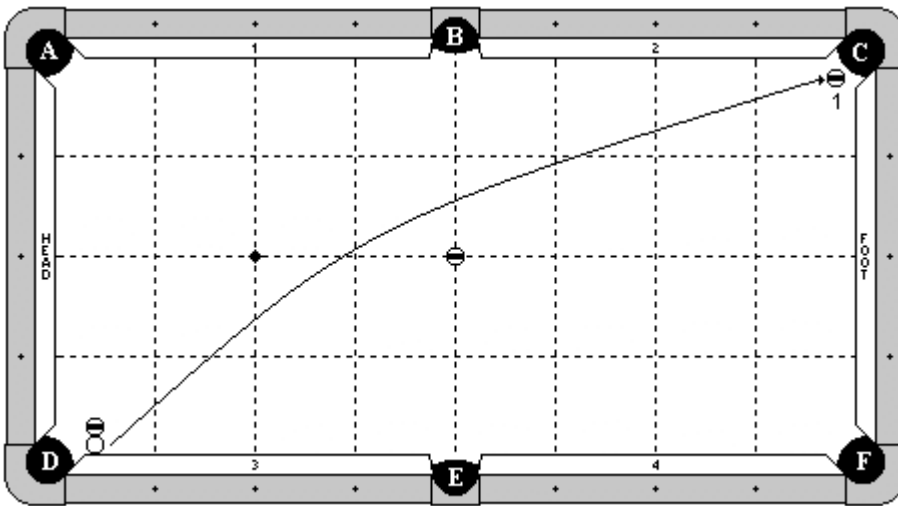

Cue Ball

Frozen to the cushion, with the edge aligned with the pocket point.

Object Balls

A blocker ball is frozen to the cue ball and perpendicular to cushion 3 (straight out). Another blocking ball is on the center point of the table. The 1 ball is hanging near pocket 'C'.

Objective

Shoot the cue ball into cushion 3, compressing the rail and allowing the cue ball to escape. The cue ball will travel around the center blocking ball as diagrammed, and make the 1 ball.

Special Notes

Neither blocking ball may move by any means until after the 1 ball is made.

Discipline 8 – Shot 1c – 6 points

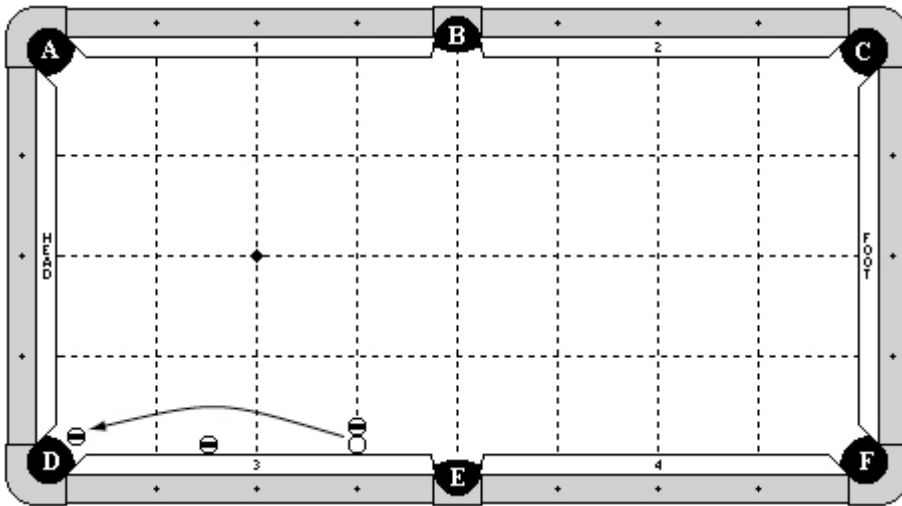

Cue Ball

Frozen to cushion 3 – one diamond from pocket 'E'.

Object Balls

An object ball is hanging in pocket 'D'.

One blocker ball is frozen to cue ball, directly in line along the diamond line. One blocker ball is frozen to cushion 3 at 1/2-diamond segments from pocket 'D'.

Objective

Masse the cue ball such that it escapes from between the blocking ball and rail and curves around the other blocking ball to make the object ball hanging in pocket 'D'.

Special Notes

The blocking balls may not move by any means until the shot is complete.

Discipline 8 – Shot 2a – 7 points

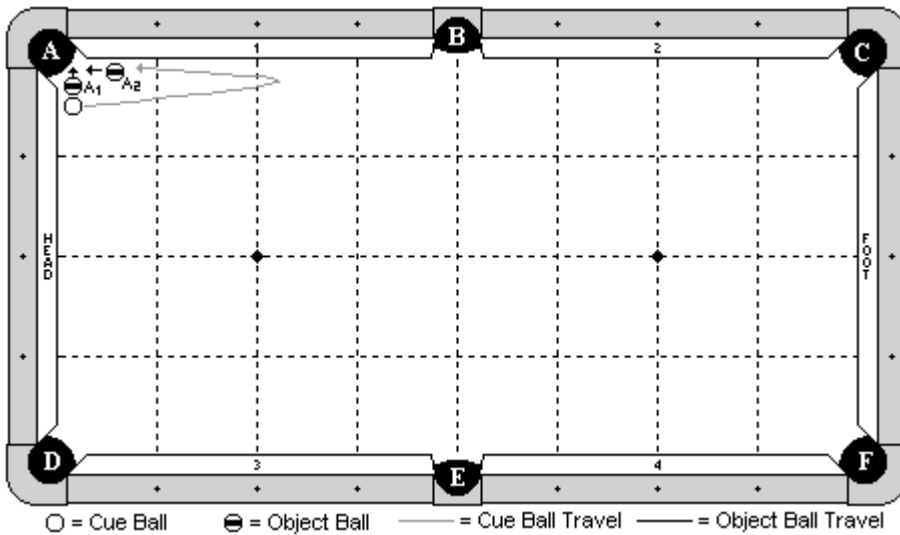

Cue Ball

In hand

Object Balls

Both object balls are in hand as diagrammed.

Objective

Execute a full masse, first making 'A1' ball, having the cue ball come out and back, and then making 'A2' ball. The cue ball may not come back by hitting the far pocket point of pocket 'B', nor may it come back by hitting any part of the foot cushion. The cue ball may contact cushion 1 or 2, but no other, until both balls have been made.

Special Notes

This is a masse shot. Players may not position the balls in such a way that they will both go in with a simple stroke. Players must elevate and make 'A1' ball first, then have the cue ball masse out and back to make 'A2' ball. This shot may be done from any corner, but it may not be rotated. In other words, 'A2' ball must be along cushions 1,2,3 or 4. It may not be along the head or foot cushion.

Discipline 8 – Shot 2b – 7 points

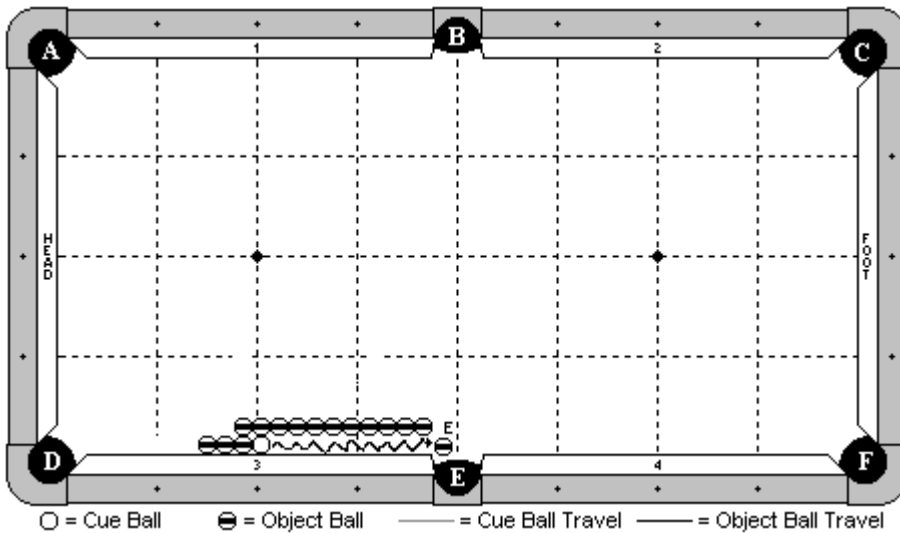

Cue Ball

Frozen to cushion 3 and to two other object balls next to it as diagrammed.

Object Balls

Three object balls are to the left of the cue ball, all frozen in line and to the cushion. 11 object balls are frozen in line exactly 1 ball's width from cushion 3. The 11th ball is frozen to the object ball that is next to the cue ball. The 1st object ball in line may start anywhere to the left of the B-E center line. 'E' ball is hanging near pocket 'E' and is adjustable.

Objective

Masse the cue ball, causing the three balls to the left of the cue ball to move. The cue ball will masse back and finally make 'E' ball.

Special Notes

The cue ball must make 'E' ball, not another object ball. There is no requirement on how many balls must move, but players must setup the shot with the line of balls exactly 1 ball's width off the cushion, and they must execute the shot with a full (or close to full) masse stroke.

Discipline 8 – Shot 2c – 7 points

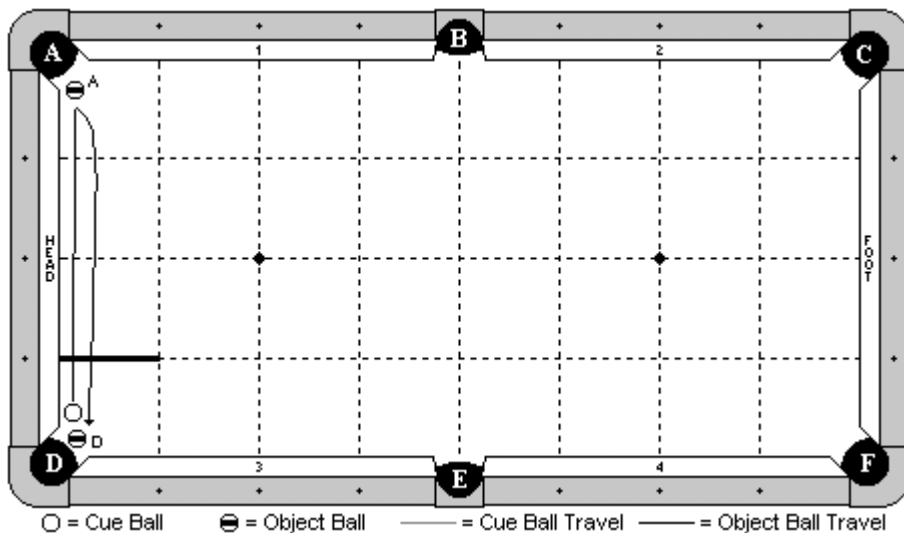

Cue Ball

In hand behind the indicated line.

Object Balls

'A' ball is in hand near pocket 'A', but the base of the ball may not go past the head rail pocket point. It also may not be more than 1 chalk's width off the head cushion. 'D' ball is hanging near pocket 'D'.

Objective

Masse the cue ball to make 'A' ball. The cue ball will masse back and make 'D' ball.

Special Notes

Players must execute a full masse. This shot may not be done with a draw stroke.

Discipline 8 – Shot 3a – 8 points

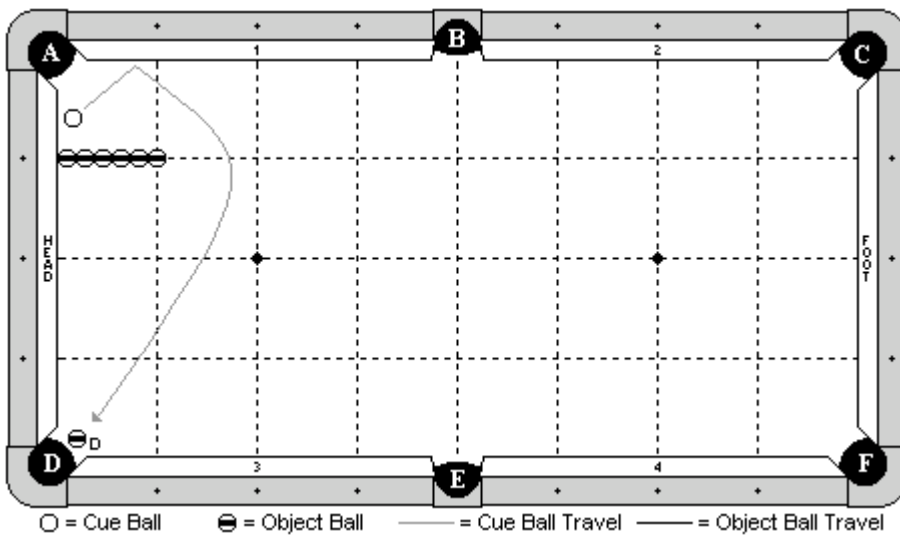

Cue Ball

In hand between the line of balls and cushion 1. It may not be more than 1 ball's width off the head cushion.

Object Balls

6 blocker balls are frozen in line along the 1st diamond as diagrammed. The first ball is frozen to the head cushion. 'D' ball is hanging near pocket 'D'.

Objective

Masse the cue ball into cushion 1. It will then bounce out and around the blocker balls, and make 'D' ball.

Special Notes

The blocker balls may not be touched by any means until after 'D' ball is made. The cue ball may not contact the foot cushion until after 'D' ball is made.

Discipline 8 – Shot 3b – 8 points

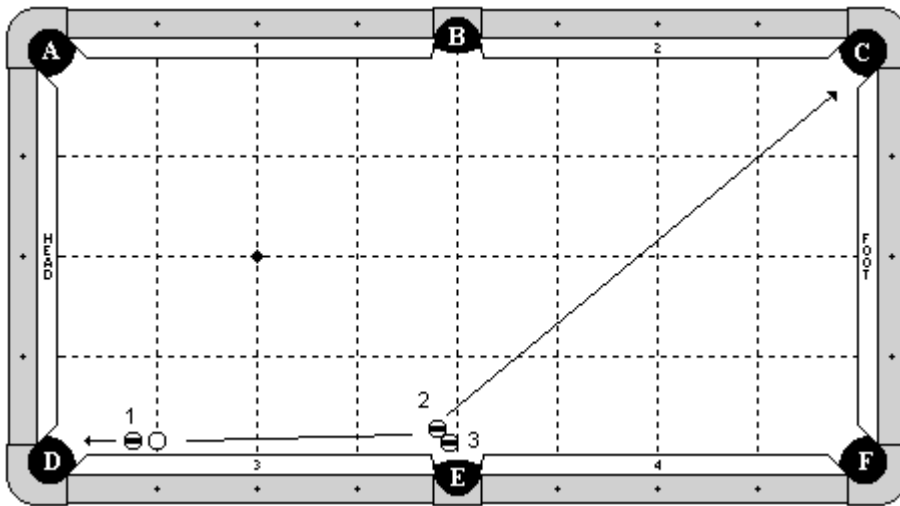

Cue Ball

On the first diamond line, no more than 1 chalk's width from the cushion.

Object Balls

1 ball is in hand, but must be at least 1 chalk's width from the cue ball. The 2 and 3 balls are in hand near pocket 'E'.

Objective

Masse the cue ball, making the 1 ball in pocket 'D'. The cue ball will masse back into the 2 ball, making it in pocket 'C' and making the 3 ball in pocket 'E'.

Special Notes

Players must use a full masse stroke for this shot. They may not use a draw stroke.

Discipline 8 – Shot 3c – 8 points

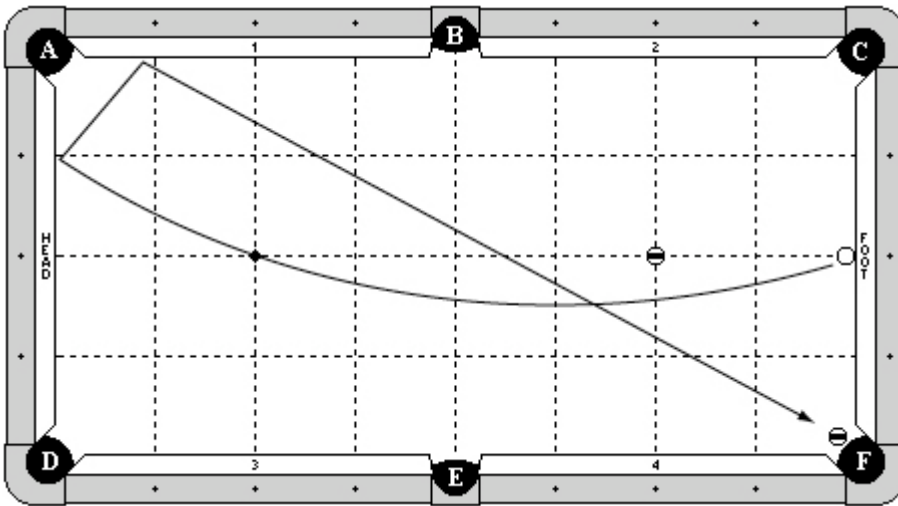

Cue Ball

Frozen to foot cushion at second diamond.

Object Ball

One object ball hanging in pocket 'F'.

A blocker ball is on the foot spot.

Objective

Masse the cue ball around the blocking ball, hitting the head cushion and cushion 1, and making the hanging ball in pocket 'F'.

Special Notes

The cue ball may contact an extra cushion by pocket 'F'.

The blocker ball may not be contacted by any means until 'F' ball is pocketed.

Discipline 8 – Shot 4a – 9 points

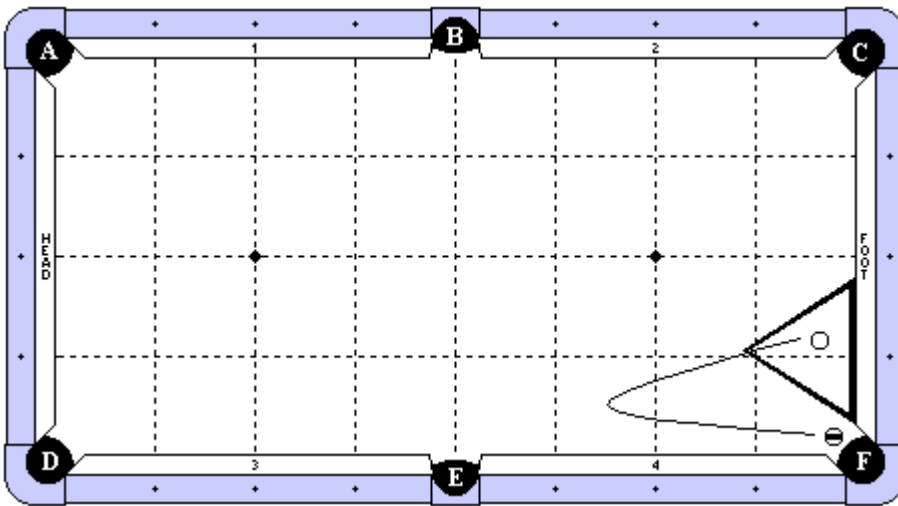

Cue Ball

In hand within the rack.

Object Balls

An object ball is hanging near pocket 'F'. A rack is placed frozen to the foot cushion as diagrammed.

Objective

Hit the cue ball with a jump masse stroke. It will jump out of the rack, turn around and come back to make the object ball in pocket 'F'.

Special Notes

The rack may not be touched when the cue ball is jumping out of it, but it may be contacted when the cue ball comes back to make the object ball. The cue ball's trailing edge must completely pass the 2nd diamond line. Decision by the referee is final. The cue ball may contact cushion 3 or 4, but none other until 'F' ball is made. The cue ball may not come back because it hit the far pocket point of pocket 'E'. Decision by the referee is final.

Discipline 8 – Shot 4b – 9 points

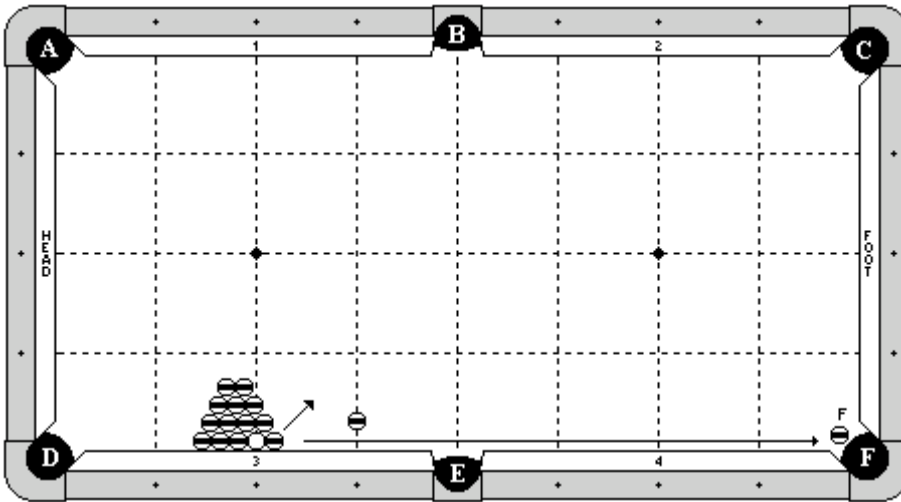

Cue Ball

Frozen to the cushion and at the 2nd diamond, as diagrammed.

Object Balls

13 object balls are placed in a standard rack formation (with the head ball missing) around the cue ball as diagrammed. A blocker ball is on the 3rd diamond and exactly 1 ball + 1 chalk's width from the cushion. 'F' ball is hanging.

Objective

Masse the cue ball, causing the balls in the rack to scatter. The end ball will get out of the way, and the cue ball will masse along the cushion, between the blocker ball and the cushion, and make 'F' ball.

Special Notes

Players must perform a full masse. Masse stroke must be performed in one fluid motion. It is possible for the tip to graze the blocker ball to the right of the cue during the downward stroke but it is not legal to swipe the blocker ball out of the way with the side of the cue stick. The blocker ball may not be hit by any means until after 'F' ball is made. The 'F' ball must be made by the cue ball. It may not be made by an object ball.

Discipline 8 – Shot 4c – 9 points

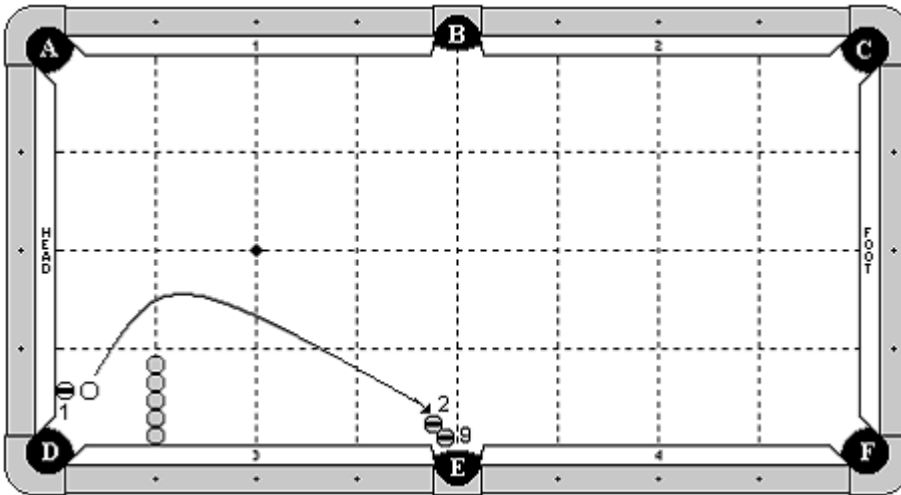

Cue Ball

In hand, but may not be frozen to 1 ball.

Object Balls

1 ball is frozen to the head cushion, $\frac{1}{2}$ diamond from pocket 'D'.

2 and 3 balls form a combination by pocket 'E'.

Five blocker balls are frozen in a line off of rail 3, one diamond segment from pocket 'D'.

Objective

Shoot the cue ball into 1 ball. The cue ball will carom around the blocker balls and masse back to make the 3 ball in pocket 'E'.

Special Notes

The cue ball may not touch the blocker balls until 3 ball is made.

The 1 ball may contact the blocker balls.

The cue ball may contact the 2 or 3 ball first, so long as the 3 ball is pocketed.

Discipline 8 – Shot 5a – 10 points

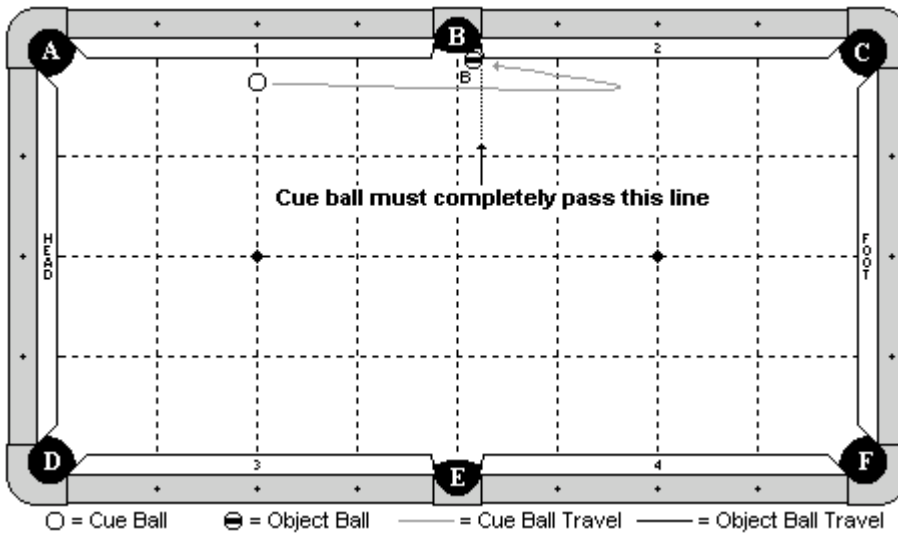

Cue Ball

Base of the cue ball is on the 2nd diamond line or to the left of it (towards the head cushion). It may not be more than 1 ball's width from cushion 1.

Object Balls

'B' ball is placed frozen to the pocket point, and with the edge aligned with the pocket cut. This ball must be placed exactly as described. Players are not free to adjust this ball.

Objective

Masse the cue ball past the object ball. It will then come back and make 'B' ball in pocket 'B'.

Special Notes

The trailing edge of the cue ball must completely pass the forward edge of the object ball (as indicated by the line drawn). Table judge will make the final call. The cue ball may contact cushion 1 or 2, but no other, until after 'B' ball is made.

Discipline 8 – Shot 5b – 10 points

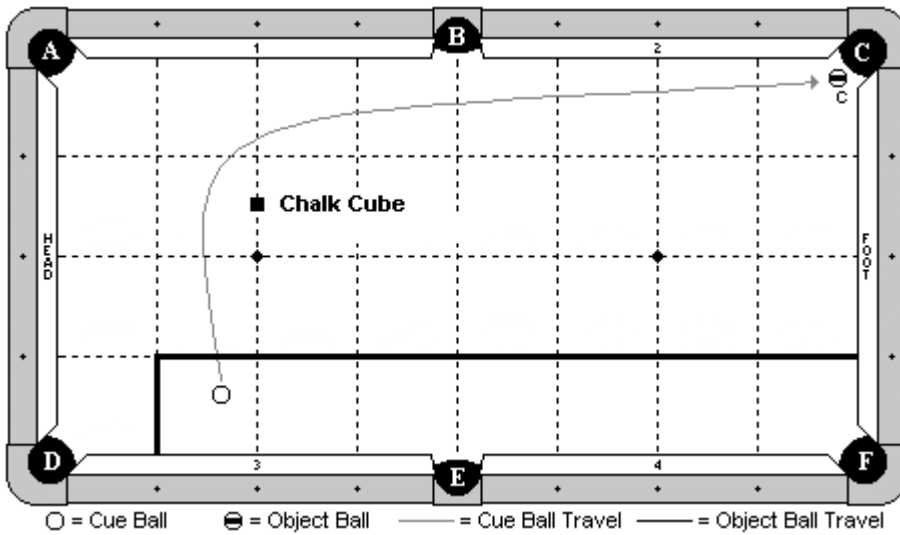

Cue Ball

In hand within the indicated zone.

Object Balls

'C' ball is hanging. A piece of chalk is placed square to the table along the head string, exactly $1\frac{1}{2}$ diamonds from cushion 1.

Objective

Masse the cue ball around the chalk, along the indicated path, and make 'C' ball.

Special Notes

The chalk may not be contacted by any means until after 'C' ball is made. The cue ball may not contact the head cushion until after 'C' ball is made.

Discipline 8 – Shot 5c – 10 points

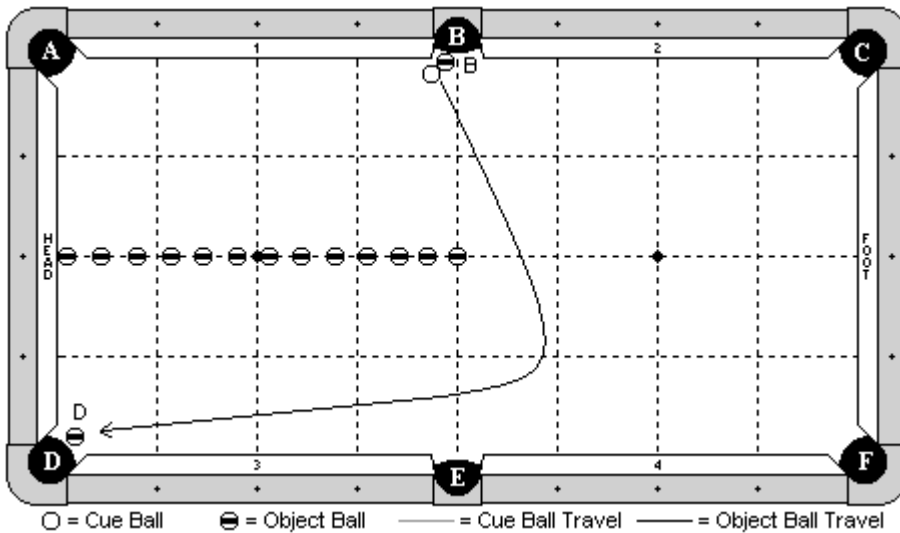

Cue Ball

In hand, frozen to 'B' ball.

Object Balls

'B' ball is in hand near pocket 'B', but must be to the left of the B-E center line. 'D' ball is hanging near pocket 'D'. 13 blocker balls are placed along the long center line of the table. The first ball is frozen to the head cushion. The last ball is on the exact center spot of the table. The other balls are evenly spaced.

Objective

Masse the cue ball, making 'B' ball. The cue ball will travel around the blocker balls as diagrammed, and make 'D' ball.

Special Notes

The blocker balls may not be touched by any means until after 'D' ball is made.

Tiebreaker Shot / Challenge

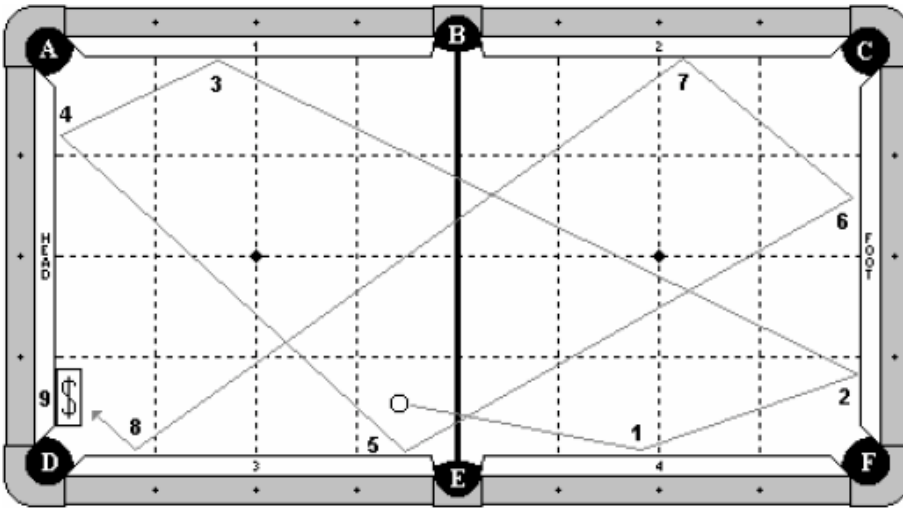

Cue Ball

The cue ball is in hand and anywhere behind centerline ('B' – 'E').

Object Balls

No object balls are in this challenge. A dollar bill is placed on the table so that its edge is even with the head cushion nose. The center of bill is halfway between pocket 'D' and the 1st diamond from pocket 'D'.

Objective

Tied players will get 1 attempt to shoot the cue ball 8 or 9 cushions in diagram pattern to dollar bill. The player that lands his or her cue ball closest to the center of the dollar bill wins this challenge. Table judge decision is final.

Special Notes

Tied players will lag to determine who goes first. Winner of lag has choice of shooting first or last.

Cue ball must contact either the 8 or the 9 cushions. Contact with one is required. Contact with both is optional. In other words, an exception to the diagramed cue ball travel may result if the head cushion is hit as the 8th cushion and the #3 cushion is not hit near pocket D. In addition, cue ball may hit cushion #4 as the 5th cushion hit.

The vertical edge of the cue ball closest to the dollar bill center will determine the "measured" distance for comparing all player rolls.

If none of the tied players hits 8 or 9 cushions, then the shot will be done over with another lag between the tied players to see who goes 1st with the lag winner having choice again of shooting first or last.

PLAYER AUTOGRAPHS / SPECIAL MESSAGES

READY...

SET...

SHOOT...

